

Easy Nest Kits

Installation Suggestions



General Recommendations

Hydraulics

- Vacuum breakers should be installed to prevent siphoning.
- Flexible connectors should follow FRP tank manufacturers recommendations.

Electrical

- Supply of electricity should be compatible with the voltage required by the controller.
- Comply with local electrical codes and ensure an uninterrupted supply of power is available.

Plumbing

- Proper piping practices should be used on media tanks.
- Comply with local plumbing codes and follow common practices while plumbing the components.
- Teflon tape should be used on threads for **cast iron** Easy Nest Kits.
- **Do not** use Teflon tape on **plastic** Easy Nest Kits.

Floor Drain

- Units should be located close to a clean working drain.
- The drains capacity should be checked for accepting backwash and Fast Rinse flows.
- An air gap should be installed on the drain to prevent backflow contamination.
- The systems drain line should be less than a 15-foot pipe length equivalent.
- Elevation of the drain line should be less than five feet above the injector.

Floor

- The floor should be able to support the installation weight of the system and be fairly level.

Isolating/Bypass Valving

- A manual bypass around the system for easy servicing and emergencies is recommended.

Matching Flanges

- Companion flanges are not included for large valves.

Upper and Lower Distributors/False Bottom

- Follow component manufacturers recommendations.

Media Tanks

- Steel and FRP tanks can be used if proper piping practices are followed.

New System Check Out and Troubleshooting Guide

This is a guide for starting a system after all of the initial installation is completed:

- Plumbing is complete including raw water supply (inlet), Service (outlet), drain (including Drain Line Flow Control), and regenerate draw line. The brine tank and brine valve are installed, however no salt has been added at this time. A sufficient amount of water should be added to the brine tank so the water level is above the salt grid (if installed).
- The media tanks are loaded and the tanks are filled with water.
- Control Pressure to stager is connected to a constant source that is equal or larger than line pressure. Drain port of stager is open to atmosphere. For trouble-free operation, the use of a 5-micron filter, in the control pressure line is recommended.
- All necessary diaphragm valve/stager tubing has been connected.
- The control has power available but is not powered up at this time.

System Check Out

1. Manually advance stager to the Backwash Position by rotating the cam counterclockwise.
2. Open feed water supply valve fully (tanks have already been filled with water prior to this step). Water should flow to drain at Backwash flow rate, which is determined by a Drain Line Flow Control installed in the drain line. Water to Service should stop after several seconds. If water continues to Service refer to Section 1 of the Troubleshooting guide.
3. Backwash system until water to drain runs clear. Observe that no media is being washed to drain. If media is being washed to drain, turn feed water supply off immediately and refer to Section 2 of the Troubleshooting guide.
4. Manually advance stager to Draw/Slow Rinse position. Flow of water to drain should decrease substantially. Water level in the brine tank should begin to go down. After verifying draw rate please move to next step.
 - If flow to drain does not decrease refer to Section 3 of the Troubleshooting guide.
 - If level in brine tank does not go down refer to Section 4 of the Troubleshooting guide.

5. Manually advance stager to Fast Rinse. Flow to drain should increase to the level it was during Backwash. If the flow does not increase refer to Section 5 of the Troubleshooting guide.
6. Manually advance stager to Service position.
7. Apply power to controller.
8. If Electro-Mechanical controller (with A100 timer) is used, set the regeneration time, days of regeneration and individual cycle times on the timer. Refer to A100 Stager Control Manual.
9. If Electronic controller (with 962 timer) is used, follow instructions as outlined in 962 programming manual.
10. System Check Out is complete and may be placed into service.
11. Open Service outlet valve.

Troubleshooting Guide

Section	Symptom	Probable Cause	Correction
1	Water to service, no water to drain or water to both service and drain.	Tubing from stager to diaphragm valves may be incorrect. Refer to nest diagram, valves 3 and 4 tubing should not have pressure to them, all others should have pressure.	Refer to Manual to identify and correct tubing mistake.
2	Media washing to drain.	No drain line flow control is installed or drain line flow control is not sized correctly for media and/or water temperature.	Check for drain line flow control in drain line. Refer to media specification sheet for proper backwash rate.
3	Flow to drain does not decrease in draw cycle.	Tubing from stager to diaphragm valves may be incorrect. Refer to nest diagram, tubing going to valves 5 and 6 should not have pressure to them, all others should have pressure.	Refer to manual to identify and correct tubing mistake.
4	Level in brine tank does not go down.	Tubing from stager to diaphragm valves may be incorrect. Refer to nest diagram, tubing on valves 5 and 6 should not have pressure to them, all others should have pressure. Brine valve may be preventing draw.	Refer to manual to identify and correct tubing mistake. If tubing is correct examine brine valve instruction sheet for troubleshooting information regarding the brine valve.
5	Flow to drain does not increase to the level it was during Backwash.	Tubing from stager to diaphragm valves may be incorrect. Refer to nest diagram, tubing on valves 1 and 6 should not have pressure to them, all others should have pressure.	Refer to manual to identify and correct tubing mistake.

Existing Easy Nest System Troubleshooting Guide

Preliminary Checklist

Check to make sure:

- Vent ports on the diaphragm valves are not plugged or obstructed.
- Stager drain port is open to atmosphere.
- Controller has uninterrupted power source.

- Control pressure is equal to or greater than the system pressure and is a constant source.
- Systems using Easy Nest Kits consist of Normally Open type Diaphragm Valves controlled by pressure/vent signals from the stager control ports. Check for stager signal (pressured/vented) on valves by disconnecting tubing from the stager port connected to the valve. If upper diaphragm chamber (valve cap) is pressurized, valve should be closed and if vented, it should be open.

Problem	Possible Cause	Solution
1. Failure to draw brine.	<ul style="list-style-type: none"> a. Rinse outlet, valve No. 6, not opening. b. Back pressure on injector. c. Low water pressure. d. Service inlet, valve No. 1, not closing. e. Backwash inlet, valve No. 4, not closing. 	<ul style="list-style-type: none"> a. Check for control signal on valve No. 6. If pressured, check stagers operation. If vented, disassemble and repair valve. b. Drain line flow controller restricted or too small. c. Inlet pressure must be at least 30 psi. d. Check for control signal on valve No. 1. If pressured, check stagers operation. If vented, disassemble and repair valve. e. Check for control signal on valve No. 4. If pressured, check stagers operation. If vented, disassemble and repair valve.
2. Mineral discharge to service.	<ul style="list-style-type: none"> a. Bottom distributor in media tank damaged or broken 	<ul style="list-style-type: none"> a. Check and replace distributor.
3. Mineral discharge to drain.	<ul style="list-style-type: none"> a. Backwash flow control missing b. Backwash flow control oversized c. Change in water pressure (If fixed orifice type, backwash flow controller is used) 	<ul style="list-style-type: none"> a. Check drain line of flow controller. b. Check for proper sizing of flow controller. c. If system has pressure fluctuation, install properly sized flow control in the drain line.
4. Change in water temperature.	<ul style="list-style-type: none"> a. Water temperature. 	<ul style="list-style-type: none"> a. If water temperature is changed, adjust backwash flow rate per specification supplied by media manufacturer.
5. Low service flow rate and/or high pressure loss.	<ul style="list-style-type: none"> a. Service inlet and outlet, valve No. 1 and 2, not opening. 	<ul style="list-style-type: none"> a. Disconnect tubing from stager ports 1 and 2. If pressured, stager is malfunctioning, repair stager. If stager port 1 and 2 are vented, check valve No. 1 and 2, repair valves.
6. Poor quality water to service.	<ul style="list-style-type: none"> a. Backwash inlet, valve No. 4, not closing. b. Unit not regenerating. c. No brine draw. d. Lack of brine/salt in brine tank. 	<ul style="list-style-type: none"> a. Disconnect tubing from stager port No. 4. If pressured, stager is malfunctioning. If vented, check valve No. 5 and repair. b. Check controller operation and regeneration frequency setting. c. Check brine valve operation. d. Check salt level. Fill brine tank, if necessary.
7. Unit will not regenerate automatically.	<ul style="list-style-type: none"> a. No electric power to timer. b. No flow indications (E9XX controller only). c. Control not programmed correctly. 	<ul style="list-style-type: none"> a. Check electrical power supply for interruption. b. Check flow meter. c. Program control, see control manual.

8. Leak to drain.	<ul style="list-style-type: none"> a. Backwash outlet and/or rinse outlet valve not closing. b. Insufficient or lack of control pressure to stager. 	<ul style="list-style-type: none"> a. Disconnect tubing from stager ports 3 and 6. If vented, stager malfunctioning. If pressured, check valve and repair. b. Check control pressure to the stager, must be equal to or greater than line pressure to valves.
9. Salt in service line.	<ul style="list-style-type: none"> a. Not enough rinse time. b. Brine draw rate too slow. c. Back pressure on injector. d. Salt dosage too high. 	<ul style="list-style-type: none"> a. Check slow rinse and fast rinse time, adjust if necessary. b. Back pressure on injector. c. Check backwash flow controller or obstruction and remove obstruction. d. Check and adjust salt dosage.
10. Brine tank overflow.	<ul style="list-style-type: none"> a. Brine valve malfunctioning. 	<ul style="list-style-type: none"> a. Repair or replace brine valve.
11. Valve operation erratic or slow.	<ul style="list-style-type: none"> a. Insufficient control pressure to stager. b. Stager drain port restricted or plugged. 	<ul style="list-style-type: none"> a. Check control pressure to the stager, must be equal to or greater than line pressure. b. Check stager drain for restriction and/or obstruction.
12. Improper or no backwash flow.	<ul style="list-style-type: none"> a. Backwash flow controller plugged or obstructed. b. Backwash valves 3 and 4 not opening. 	<ul style="list-style-type: none"> a. Check backwash flow controller for obstruction and remove obstruction. b. Check stager port connected to valves 3 and 4. It should be vented. If pressured, check stager operation. If vented, check and repair diaphragm valve.
13. Improper or no fast rinse flow.	<ul style="list-style-type: none"> a. Backwash flow controller plugged or obstructed. b. Rinse outlet, valve No. 6, not opening. 	<ul style="list-style-type: none"> a. Check backwash flow controller for obstruction and remove obstruction. b. Check stager port connected to valve 6. It should be vented. If pressured, check stager operation. If vented, check and repair diaphragm valve.
14. Poor water quality.	<ul style="list-style-type: none"> a. Service flow rate too high. b. Media bed channeling or scaled. 	<ul style="list-style-type: none"> a. Check and adjust flow rate, if necessary. b. Backwash media to reclassify media bed and check media condition.

Component Troubleshooting

Introduction

The E-Z Nest Kit consists of three main components, Diaphragm Valves, Injector (for softeners) and Stager Controller. Troubleshooting guide for all three components is outlined below.

Diaphragm Valves

Problem	Possible Cause	Solution
1. Valve not closing.	<ul style="list-style-type: none"> a. Insufficient control pressure from stager port. b. Valve disc damaged. c. Vent port plugged or obstructed. 	<ul style="list-style-type: none"> a. Check stager ports & tubing for obstruction. b. Disassemble valve and replace disc. c. Remove plug from vent port and check vent port for any obstruction, clear obstruction.
2. Valve operation slow or sluggish.	<ul style="list-style-type: none"> a. Tubing from stager is obstructed. b. Vent port obstructed. 	<ul style="list-style-type: none"> a. Remove obstruction. b. Remove obstruction.
3. Water leak through vent port when valve is closed. Water leak through vent port when valve is open.	<ul style="list-style-type: none"> a. Damaged diaphragm. b. Leak through the dynamic O-Ring. 	<ul style="list-style-type: none"> a. Replace diaphragm. b. Disassemble valve and replace O-Ring.
4. Water hammer when valve closes.	<ul style="list-style-type: none"> a. Excessive control pressure. 	<ul style="list-style-type: none"> a. Reduce control pressure, must be equal to system pressure.
5. Valve does not open.	<ul style="list-style-type: none"> a. Stager drain port plugged or restricted. 	<ul style="list-style-type: none"> a. Check and remove restriction from the stager drain port.

Stager

Problem	Possible Cause	Solution
1. Continuous leak to drain.	<ul style="list-style-type: none"> a. Foreign material between stem plate and gasket. b. Stem plate and/or gasket worn or damaged. 	<ul style="list-style-type: none"> a. Clean & remove the foreign material. b. Replace damaged parts.
2. Stager out of position, or not stopping at correct position. Stager not advancing.	<ul style="list-style-type: none"> a. Misaligned or damaged switch. b. Damaged motor. 	<ul style="list-style-type: none"> a. Align switch replace switch if damaged. b. Replace motor.
3. Stager ports not venting.	<ul style="list-style-type: none"> a. Restriction in tubing. b. Stager drain port plugged or restricted. 	<ul style="list-style-type: none"> a. Check and remove restriction. b. Check stager drain port and remove restriction.
4. No pressure at control ports. Low control pressure at the control ports.	<ul style="list-style-type: none"> a. Restricted or plugged control line to the stager. Control pressure must be equal to line pressure of the system. 	<ul style="list-style-type: none"> a. Remove restriction.

Controller

Refer to the controller manual.

4 POSITION SOFTENER (48-00 STAGER)

NOTCH POS.	FUNCTION	PORTS VENTED (NOTE 1)	VALVES OPEN
A	4 SERVICE	1,2	1,2
B			
C	1 BACKWASH	3,4	3,4,2A
D			
E	2 BRINE	5,6	5,6,2A
F	3 RINSE	1,6	1,6,2A

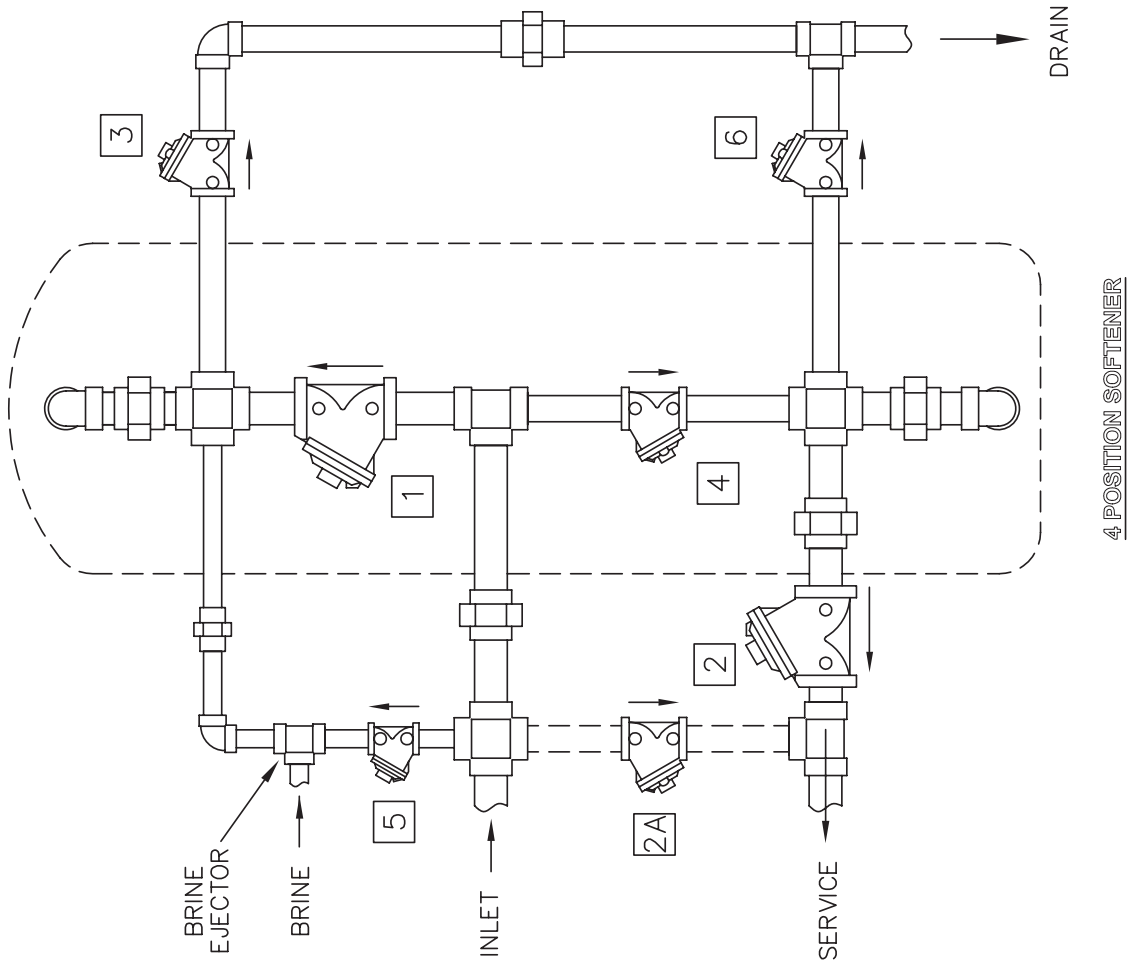
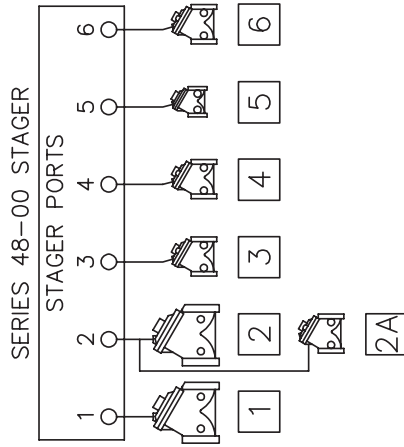

4 POSITION SOFTENER

3 POSITION FILTER (48-01 STAGER)

NOTCH POS.	FUNCTION	PORTS VENTED (NOTE 1)	VALVES OPEN
A	SERVICE	1,2	1,2
B			
C	BACKWASH	3,4	3,4,2A
D			
E			
F	RINSE	1,6	1,6,2A

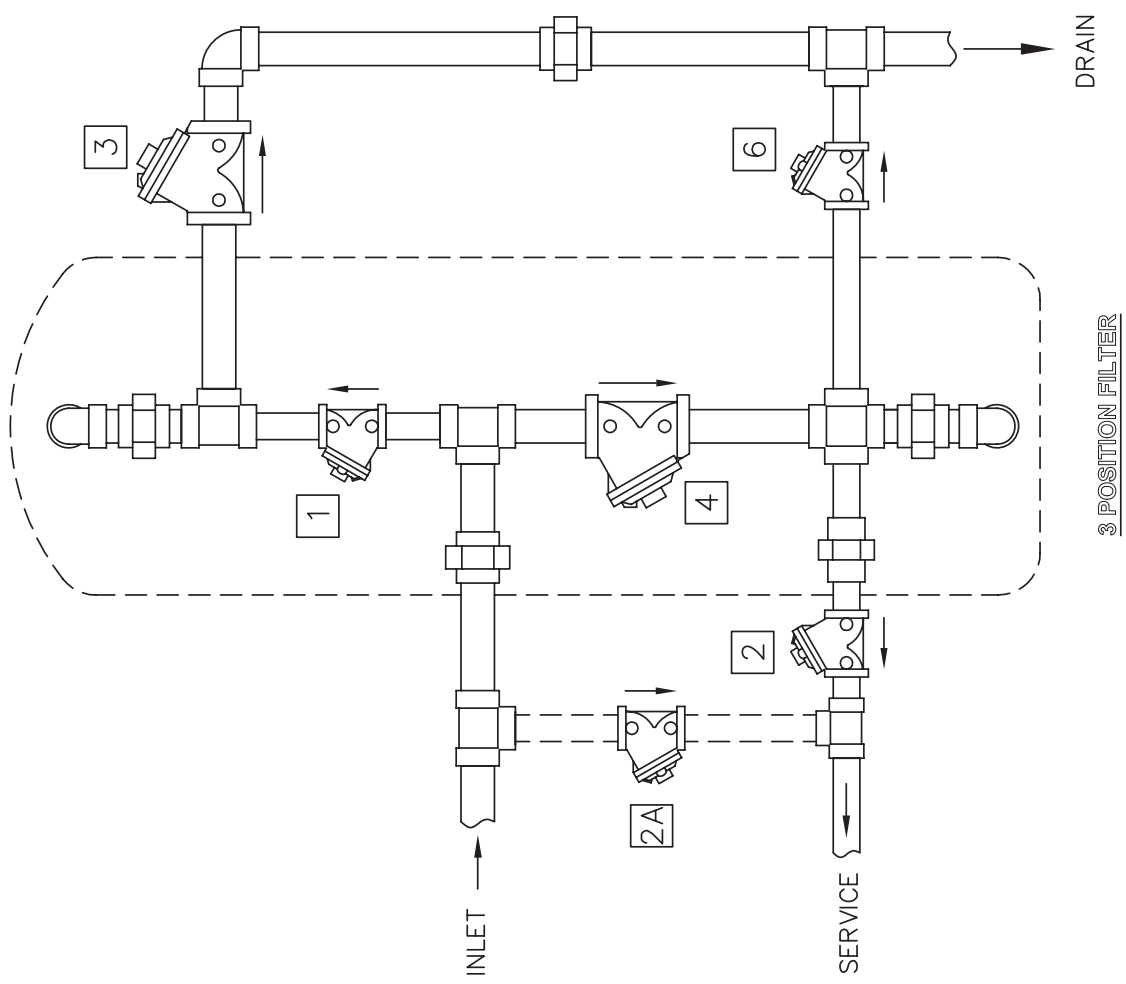
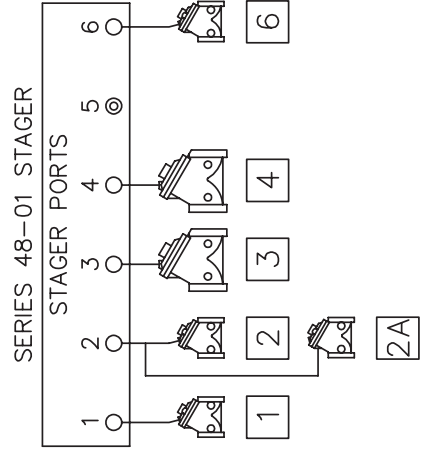

2 TANK SEQUENTIAL FILTER (51-10 STAGER)

2 TANK SEQUENTIAL FILTER

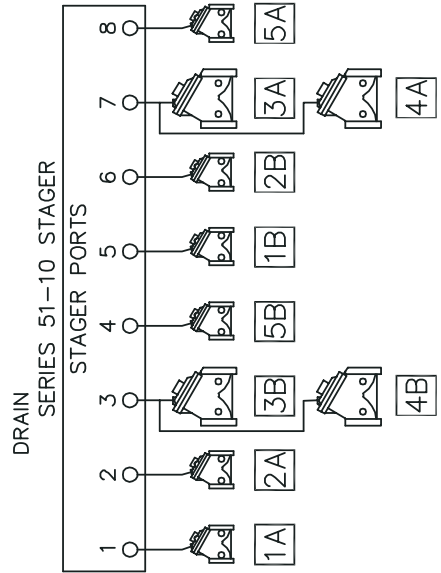
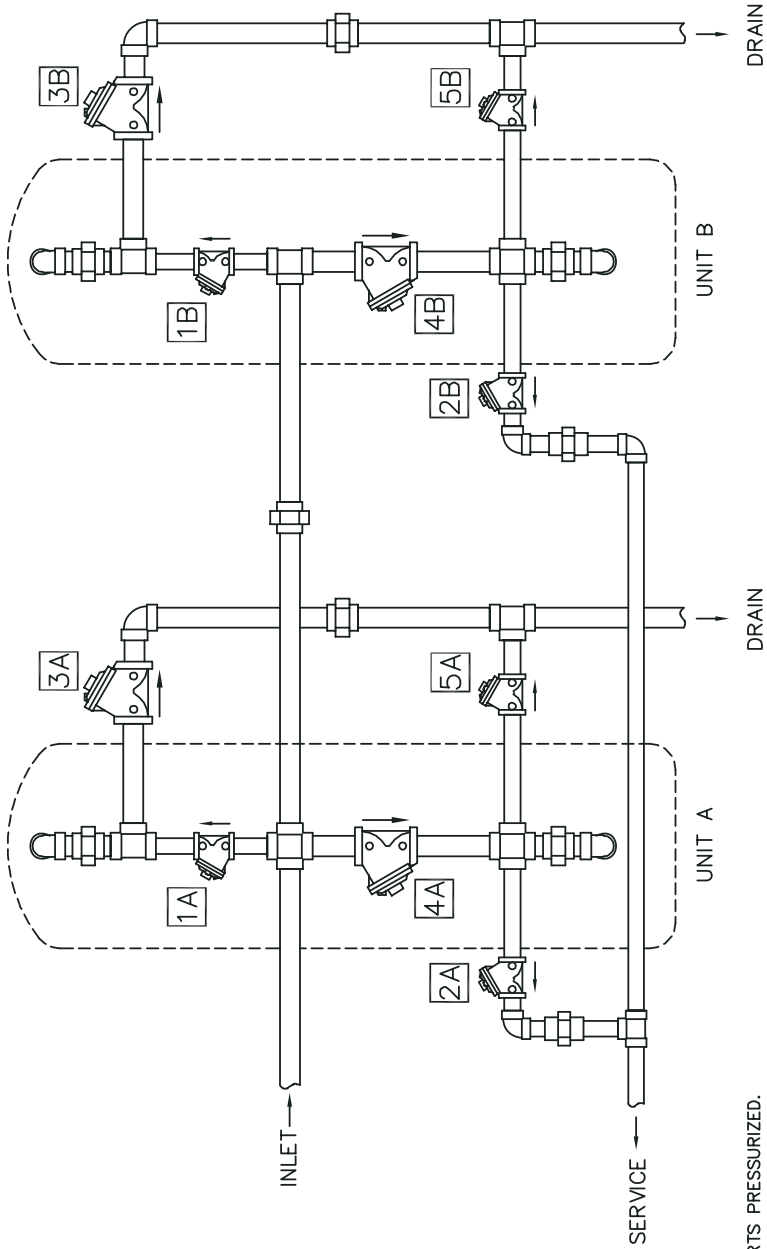

- NOTE:
1. ALL OTHER PORTS PRESSURIZED.
 2. ALL VALVES NORMALLY OPEN, PRESSURE TO CLOSE.
 3. DRAIN LINE FLOW CONTROLLER NOT SHOWN.

NOTCH POS.	FUNCTION	PORTS VENTED (NOTE 1)	VALVES OPEN
A	0 SERVICE	1,2,5,6	1A,2A,1B,2B
B			
C	1 BACKWASH UNIT A	5,6,7	1B,2B,3A,4A
D	2 RINSE UNIT A	1,5,6,8	1A,1B,2B,5A
E			
F			
G	3 BACKWASH UNIT B	1,2,3	1A,2A,3B,4B
H	4 RINSE UNIT B	1,2,4,5	1A,2A,5B,1B

3 TANK SEQUENTIAL FILTER (58-03)

3 TANK SEQUENTIAL FILTER

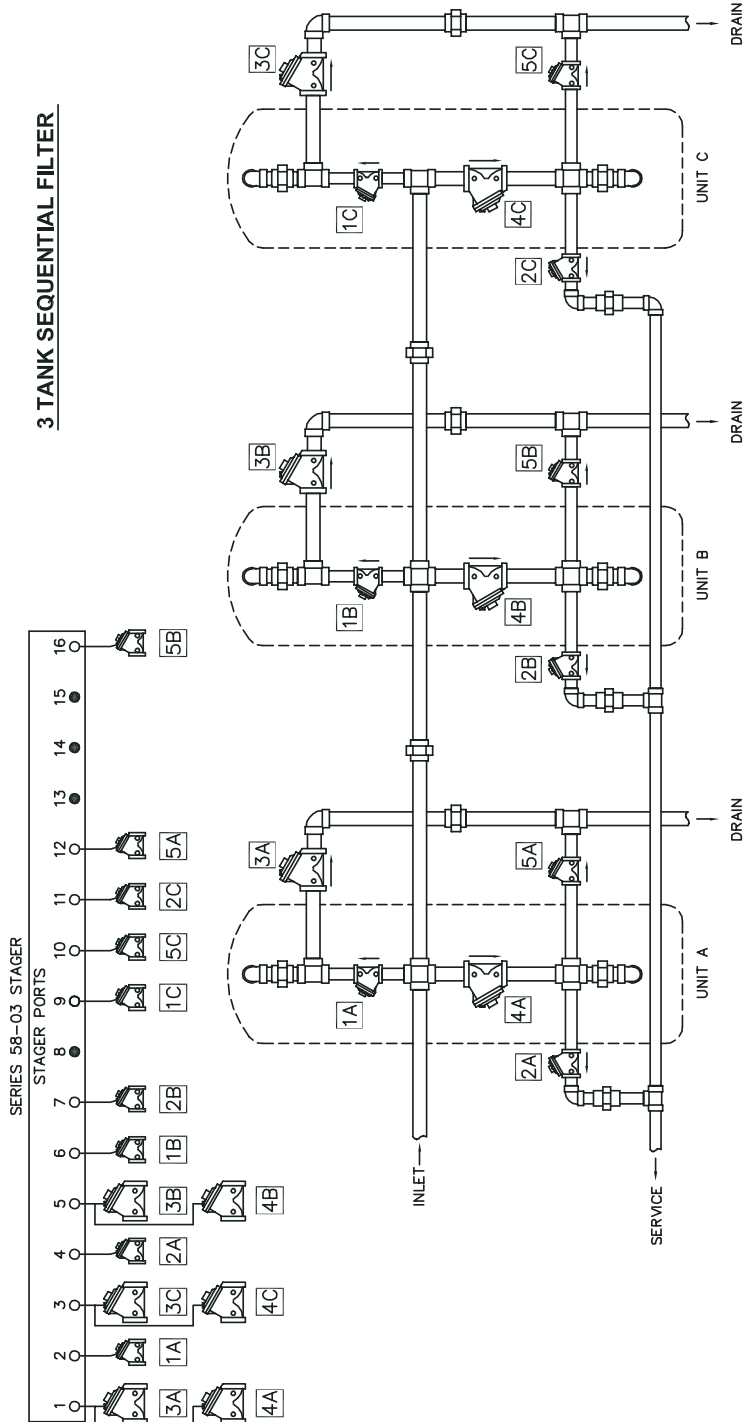

- NOTE:
1. ALL OTHER PORTS PRESSURIZED.
 2. ALL VALVES NORMALLY OPEN, PRESSURE TO CLOSE.
 3. DRAIN LINE FLOW CONTROLLER NOT SHOWN.

NOTCH	POS.	FUNCTION	PORTS VENTED (NOTE 1)	VALVES OPEN	NOTCH POS.	FUNCTION	PORTS VENTED (NOTE 1)	VALVES OPEN
A	0	SERVICE	2,4,6,7,9,11	1A,2A,1B,2B,1C,2C	J			
B					K			
C	1	BACKWASH UNIT A	1,6,7,9,11	3A,4A,1B,2B,1C,2C	L	5	BACKWASH UNIT C	1A,2A,1B,2B,3C,4C
D	2	RINSE UNIT A	2,6,7,9,11,12	1A,5A,1B,2B,1C,2C	M	6	RINSE UNIT C	1A,2A,1B,2B,1C,5C
E					N			
F					P			
G	3	BACKWASH UNIT B	2,4,5,9,11	1A,2A,3B,4B,1C,2C	Q			
H	4	RINSE UNIT B	2,4,6,9,11,16	1A,2A,1B,5B,1C,2C	R			

4 TANK SEQUENTIAL FILTER (58-04 STAGER)

