

Thank you for choosing the Pentair Water Safety Brine Valve. For a complete water conditioner system, a brine valve is indispensable for system protection and regeneration, as well as ensuring the best water conditions.

The innovative design of the Brine Valve provides safe and reliable performance, and is suitable for household and commercial conditioner systems. This manual will help you better understand the structure and properties of the valve and will guide you through the installation.

We urge you to read this manual carefully and refer to it any time a malfunction occurs. The Troubleshooting Table highlights minor problems that you can correct yourself.

Overview

The brine valve is suitable for household use. For a water conditioner system, the brine valve has two principal functions:

Air Check function - During system regeneration or a slow rinse period, the brine valve prevents air from being pulled into the resin tank, thereby ensuring the system's performance.

Refill Protection - "over-refill" may occur if the control valve was set incorrectly or a system failure occurs. If this happens, the brine valve is a protective device against overfilling the brine tank.

Product Features

- Positive automatic opening and closing of the valve by using vacuum or pressure.

- Unique mechanical structure developed according to scientific principles providing the best reliability.
- Highly expandable interface with replacement fittings, to coordinate different uses of the control valve.
- Adjustments are designed for ease of use and fast set-up.
- Flow control is regulated by the body. Brine valve is suitable for most water conditioning systems.

Specifications

Dimensions:

32" high unit: 3.2" L x 2.8" W x 27.38" H
(80 mm x 71 mm x 695 mm)

Rated Pressure: 20 - 120 psi (0.14 - 0.83 MPa)

Temperature Range: 34 - 140°F (1 - 60°C)

Used Media: Clean municipal water or brine

Max. Refill Water FLOW: 1.2 GPM (4.5 L/m)

Max. Brine Flow: 1.0 GPM (3.7 L/m)

Materials:

Main Valve: ABS & PE

Seal: Chlorine/Chloramines resistant silicone rubber

Regenerant Tube Connection

The brine valve is compatible with a 3.5" (90 mm) Pentair Water brine well, see Figure 1. The regenerant tube links the control valve and the brine valve. Place one end of the right angle elbow through the hole of the brine well. Slide the nut, retaining sleeve and plastic gripper over the regenerant tube. Insert the inner tube support and connect the regenerant tube to the elbow. Finally, connect the other end of the regenerant tube to the control valve.

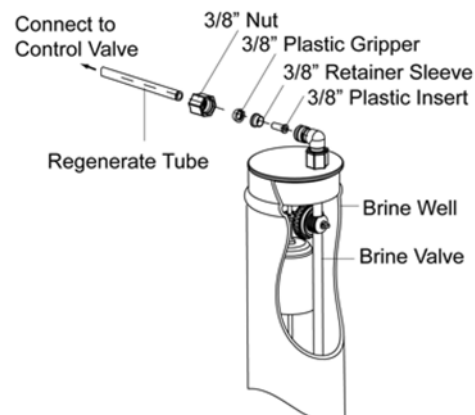

Figure 1

Brine Well Installation

1. The brine well should be vertically installed in the regenerant tank.
2. All connections should be manually tightened to ensure a solid connection. **DO NOT** over tighten plastic parts with a wrench, or you might damage plastic components.
3. Set the position of the brine valve float. The float should be positioned 0.8" - 2" (20 - 50 mm) above the brine surface level or as required for application.

CAUTION: DO NOT use petroleum based lubricants such as vaseline, oils, or hydrocarbon based lubricants. Use only 100% silicone lubricant.

Operation

The brine valve will work with the control valve to automatically control the water level in the brine tank.

Another unique feature of the brine valve is the ability to adjust the top support. The top bracket can be moved up or down by loosening the lock nut. Hand tighten the locknut.

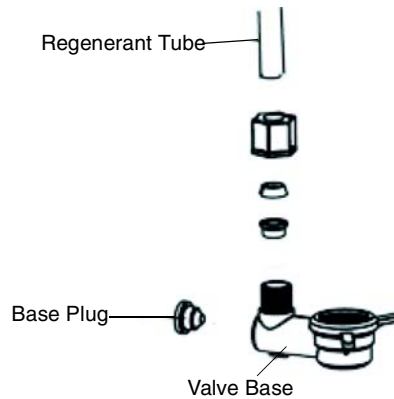
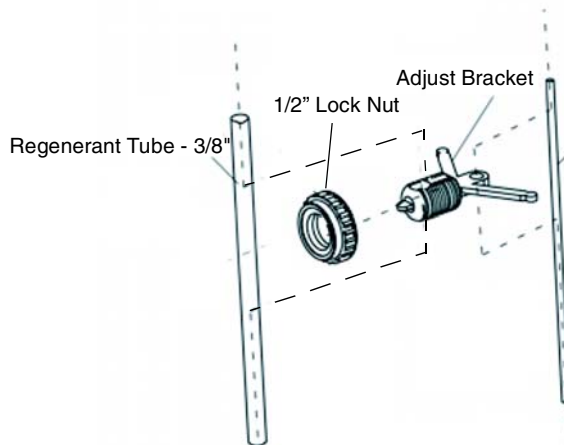

Figure 2

Disassembly



Assembly

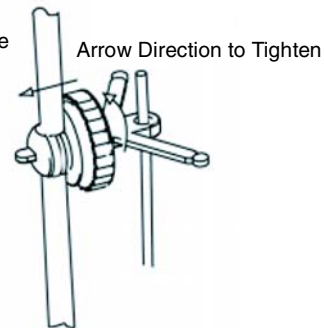
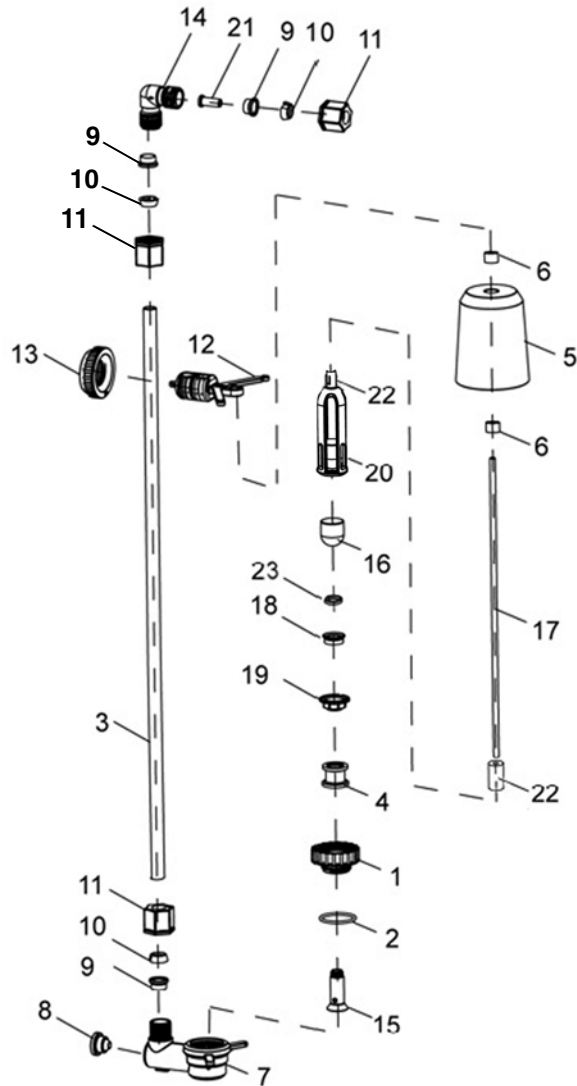

Figure 3

Troubleshooting

Problem	Possible Cause	Solutions
No water refill into the salt tank	Brine valve not operating	Check that the brine valve is vertical and moving freely.
		Water flow is greater than 1.2 gpm (4.5 L/m). Replace the refill control washer with a smaller inside diameter washer.
		Check to see if there is too much air in the resin tank.
	Obstruction in regenerant tube or valve	Inspect pipeline, remove any debris.
	Damaged brine valve	Replace brine valve.
Excessive refill	Seal leak or failure	Check for debris on seal.
		Replace the seal.
	The float does not close off incoming water	Float is restricted by the bracket. Raise top bracket to allow more space for float movement.
	Damaged brine valve	Replace brine valve.
System uses less brine than the regenerate setting	Air leak	Inspect pipeline and repair leaks.
	Regenerant tube is too long	Be sure the length is less than 6.6 ft (2 m).
	Brine valve is set incorrectly	Check and adjust floater to appropriate height.
		Be sure the refill controller is an appropriate size.
	The check ball was pulled at wrong time	Remove the check ball enclosure.

Parts



No.	Description	No.	Description
1	Threaded connector	13	1/2-inch Lock nut
2	O-Ring, 22 x 1.8	14	3/8-inch Elbow
3	Regenerant tube	15	Pole base
4	Air check seal	16	Check ball
5	Float	17	Plastic pole
6	Rubber stop	18	Inner air check seal
7	Valve base	19	Inner connector
8	Base plug	20	Inner check ball enclosure
9	3/8-inch Retainer sleeve	21	Inner tube support
10	3/8-inch Plastic gripper	22	Fastener ring
11	3/8-inch Nut	23	Inner check seal retainer
12	Support bracket		