

Autotrol 480 QC Multi-Tank Water Conditioning Control System

Installation, Operation and Maintenance Manual

Table of Contents

| | |
|---|----|
| Installation Records | 3 |
| Introduction | 4 |
| How the 480QC Operates | 5 |
| 480 Quick Connect Cables | 5 |
| QC Cable Options | |
| System Design Requirements | 5 |
| Battery Back Up | 6 |
| Lockout Switch | 6 |
| Mounting the 480QC Enclosure | 7 |
| Turbine Cable Kit Installation | 7 |
| Turbine Meter Installation | |
| Electrical Requirements | 8 |
| Magnum CV | |
| Autotrol Series 172, 180, 182 Valves | |
| Non-Autotrol Valves | |
| Line Voltage Connections | |
| Select a Multiple Tank Operating System | 9 |
| How to Program | 12 |
| Connecting the Battery Back Up | 14 |
| Final Checkout | 14 |
| Manual Regeneration | 15 |
| Resetting the 480QC | 16 |
| Specifications | 17 |
| Dimensions | 18 |
| System Drawings | 19 |
| Service and Troubleshooting Guide | 20 |
| Theory of Operation | |
| 480QC Input/Output Sockets | |
| Service Procedures | 23 |
| General Malfunctions | 25 |
| Non-Autotrol Valves | |
| Simulated Regeneration Procedures | |
| Wiring Diagram | 27 |
| Replacement Parts-NEMA 4 | 29 |

Installation Records

The 480QC is designed to monitor the volume of treated water produced by a softener or filter and initiate a regeneration or backwash at the appropriate predetermined total volume. Although some of the items listed below are not directly controlled by the 480QC, detailed records are important to effectively troubleshoot and service the system installation.

Date of Installation _____

System Type _____

Date Code _____

Water Hardness _____
(grains as CaCO₃) (ppm as CaCO₃)

Capacity (gallons)(cubic meters)
Unit 1 _____
Unit 2 _____
Unit 3 _____

Mineral Tank Size (inches)(meters)
Diameter
Unit 1 _____ Unit 2 _____ Unit 3 _____
Height
Unit 1 _____ Unit 2 _____ Unit 3 _____

Brine Tank Size (inches)(meters)
Diameter
Unit 1 _____ Unit 2 _____ Unit 3 _____
Height
Unit 1 _____ Unit 2 _____ Unit 3 _____

Salt Dosage (pounds per cubic foot)(kilograms per liter)
Unit 1 _____
Unit 2 _____
Unit 3 _____

Drain Line Flow Controller (gpm)(lpm)
Unit 1 _____ Unit 2 _____ Unit 3 _____

Injector
Unit 1 _____ Unit 2 _____ Unit 3 _____

Turbine Size _____ inch

Water Conditioner Controller Settings

| | Unit 1 | Unit 2 | Unit 3 |
|-------------|--------|--------|---------------|
| Backwash | _____ | _____ | _____ minutes |
| Brine/Rinse | _____ | _____ | _____ minutes |
| Fast Rinse | _____ | _____ | _____ minutes |

Water Conditioner Control Valve Manufacturer
Unit 1 _____
Unit 2 _____
Unit 3 _____

Water Conditioner Control Valve Model Number
Unit 1 _____
Unit 2 _____
Unit 3 _____

Introduction

The 480 Digital Demand System (DDS) is a microprocessor based controller designed to totalize effluent water usage of water conditioners. The 480QC continuously compares the programmed volumetric capacity with actual usage. When the programmed capacity is reached, the 480QC signals the water conditioner to start a regeneration.

Order options include a NEMA 4 enclosure, 1-inch or 2-inch (25 mm or 51 mm) turbine for flow measurement, English or metric units, a variety of operating voltages, quick-connect, and turbine cable lengths.

Features Include:

- A six-digit, LED display indicates system status, tank capacity, capacity remaining, and water flow rate.
- Four, switch-selectable service options:
 - Two-tank **D2 Twin Alternating** operation having one tank in service at any one time while the other tank is either in regeneration or standby following a regeneration.
 - Two-tank **E2 Twin Parallel** operation having two tanks in service except when one tank is in regeneration.
 - Three-tank **D3 Triple Alternating** operation having two tanks in service at any one time while one tank is either in regeneration or standby following a regeneration.
 - Three-tank **E3 Triple Parallel** operation having three tanks in service except when one tank is in regeneration.
- Battery-backed program storage and operation. The 480QC continues to monitor water flow for at least three hours of power outage. Refer to BACK-UP BATTERY for additional information.
- A security feature prevents the programmed settings from being changed while the status of the system is being monitored. Refer to LOCKOUT SWITCH for additional information.

How the 480QC Operates

The water turbine provides pulses that are counted by the microprocessor and converted into water usage data. The water usage data determines when a regeneration is to start. Once started, the start regeneration signal remains ON until twenty seconds after the feedback switch (mounted on the water conditioner valve) closes. While the feedback switch is **closed**, the 480QC interprets that the control valve is in regeneration and locks out any other tank from entering a regeneration. When the feedback switch **opens**, the 480QC resets the capacity to the preset value and returns the tank to service (parallel mode) or standby (alternating mode).

There are three triggers used to start regeneration, any one of which will cause the most exhausted of the tanks to go into regeneration:

1. If a tank reaches zero gallons remaining.
2. If the least exhausted tank reaches the 2-hour reserve value.
3. If there are three tanks and the least exhausted tank reaches the 4-hour reserve value, or the second least exhausted tank reaches the 2-hour reserve value, the most exhausted tank will be put into regeneration.

Note: The 2-hour reserve value is computed by accumulating the eight highest 15-minute flow periods over a 24-hour period. This one day “2-hour peak flow period” is averaged into the previous days “2-hour peak flows” and this becomes the 2-hour reserve value that is used in statements 2 and 3 above. It is important to note that the “2-hour reserve” could be derived from eight nonconsecutive 15-minute periods.

The 480QC standard program monitors the frequency of the supply voltage. If the frequency is 50 Hertz, it automatically changes to the metric version of the program. The flow rate is in Cubic Meters per Hour; the capacity is entered and displayed in Cubic Meters.

If the 480QC is installed where the supply voltage is at 60 Hertz, and the display must have a metric format, then the metric option is required. The 480QC responds as described in the above paragraph.

480 Quick Connect Cables

The quick connect (QC) cables include a 7-pin connector on one end for quick electrical connection between the 480QC and the water conditioner control valves. All power for operation of the control valves is supplied by the 480QC through the QC cables at the input voltage to the 480QC control, i.e., 24VAC, 100VAC, 120VAC, or 230VAC. **Any peripheral equipment controlled by the 480QC must be rated at the same voltage as the input voltage to the 480QC.**

The cable provides the following electrical interface between the 480QC and the water conditioner control valves:

Table-1 QC Cable

| Wire Color | Pin No. | Function |
|--------------|---------|--------------------|
| Black | 3 | Hot |
| White | 1 | Neutral |
| Green | 4 | Ground |
| Red | 2 | Start Regen Signal |
| Yellow | 5 | Isolation Signal |
| Red & Black* | 6 & 7 | Feedback Signal |

* with push-on terminals

QC Cable Options

480QC Magnum Cv™ Series

A Magnum Cv control valve configured for operation with a 480QC series includes a Model 952 impulse controller, pre-wired with the QC cable.

The black and red feedback switch wires of the QC cable have push-on terminals to connect the feedback switch mounted on the top plate of the control valve.

Series 172, 180, 182 Control Valves

The QC cables must be specified when the control valves are ordered. They will be pre-wired to the terminal block of the control valves.

Non-Autotrol Valves

This option allows the use of the 480QC with other manufacturer’s control valves. The black and red feedback switch wires of the QC cable have push-on terminal connectors that attach to a dedicated feedback switch mounted on the non-Autotrol control valves.

QC Cable Lengths

The QC cables may be ordered in lengths of 7 feet (2.1 m), 14 feet (4.3 m), or 21 feet (6.4 m).

System Design Requirements

The control mechanism of the water conditioner control valves must have a separate, unused switch that can be dedicated for use as the feedback signal. It must be capable of providing a “closed” circuit during the entire regeneration cycle and an “open” circuit during the service cycle. The switch signals the 480QC control that a regeneration is completed. The 480QC control will end the lock-out allowing regeneration of another tank, if required.

Before supplying power to the controller or control valve, check that all wiring is correct and in accordance with local codes.

The Start Regeneration Signal circuit has a rating of 200 Volt-Amps. The Start Regeneration circuit of the water conditioner control valves must be at the same voltage and phase as the 480QC controller. **If the power draw of the Start Regeneration circuit or the Isolation circuit is greater than 200 Volt-Amps, a relay interface is required.**

Battery Back-Up

During power interruptions the internal battery maintains power to the 480QC. The display goes blank, while the programmed information is retained and water usage information continues to be gathered. If power is restored in less than three hours, the 480QC recovers as if a power outage had not occurred. If the outage is longer than three hours, the display will show six "eights". All of the previous information will be lost and the controller must be reset and reprogrammed (refer to HOW TO PROGRAM).

Since the 480QC continues to monitor the water usage during a power outage, the capacity of the system may be reached or exceeded while the power is off, in which case the controller will initiate a regeneration **ONLY** when the power is restored. If the control valve was in regeneration when the power outage occurred, the regeneration will continue in the cycle in which the interruption occurred, and the 480QC resumes monitoring the feedback switch. If the control valve position was manually changed during regeneration such that the feedback switch is open when power is restored, the controller indicates, in Mode 4, that the system is in service.

Lockout Switch

The lockout switch, Figure 1, is designed to help prevent unwanted changes to the "gallons set" register in Mode 2. This is accomplished by placing the 3-position slide switch in the **locked** (center) position. In the **unlocked** (down) position, the "gallons set" register may be changed. In the **reset** (up) position, the unit is waiting for the SET button to be pushed, causing a reset of the control (refer to RESETTING THE 480QC for a complete explanation.)

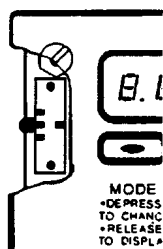

Figure 1

Mounting the 480QC Enclosure

Two distance factors must be observed when selecting a mounting location for the 480QC enclosure - the distance from the enclosure to the control valves and the distance from the enclosure to the meter turbine. Be certain that state and local codes will be met when selecting a mounting location for the enclosure.

Enclosure to Control Valves

The distance from the enclosure to the control valve will be determined by the length of the QC cable shipped with the unit. Available lengths are 7 feet (2.1 m), 14 feet (4.3 m) and 21 feet (6.4 m). To avoid strain on the QC cables, mount the enclosure one or two feet closer to the control valves than the length of the cables.

Enclosure to the Turbine Meters

The distance from the enclosure to the turbine meters will be determined by the length of the turbine cables shipped with the unit. Available lengths are 10 feet (3.0 m) and 25 feet (7.6 m). For distances over 25 feet (7.6 m) and up to the maximum allowable distance of 200 feet (61 m). Refer to TURBINE CABLE KIT INSTALLATION for details.

The enclosure may be mounted on the plumbing or on the wall. Refer to DIMENSIONS for mounting dimensions and use four No. 10 fasteners to secure the enclosure to the mounting surface.

The enclosure must be securely mounted with the faceplate vertical. Do not mount the enclosure where it is subject to excessive vibration. Maximum ambient temperature should not exceed 120°F (4°C).

Turbine Cable Kit Installation

A turbine meter cable kit is available, the 49CKT has a 25-foot (7.6-meters) turbine cable. In addition to the turbine meter cable, the kit consists of a junction box with a terminal strip and eight crimp-on wire terminal connectors. **The cable between the junction box and the 480QC enclosure is not supplied.**

The recommended cable is 22 gauge (7 x 30), tinned copper, three-conductor, shielded, and polyethylene insulated. Wire colors should be red, black and white (or clear) with a 22 gauge shield. Suggested cable is Belden No. 8771, Alpha No. 2403 or Signal No. 95216.

Refer to the wiring diagram label supplied with the kit for wire terminations.

Turbine Meter Installation

Install the turbine meter assembly in the outlet plumbing of the water conditioner so that the turbine meter cable will reach the turbine meter. Observe the flow direction arrow on the turbine meter housing; it should be pointing in the same direction as the water flow in the piping. It is recommended that there be

12 inches (304 mm) of straight pipe before the 2-inch (50-mm) turbine meter and 6 inches (152mm) of straight pipe before the 1-inch (25-mm) turbine meter. **DO NOT** use pipe compound on the turbine meter fittings.

Under normal conditions the turbine meter requires no maintenance. The use of a 50 micron "Y" strainer and/or filter before the turbine meter is strongly recommended.

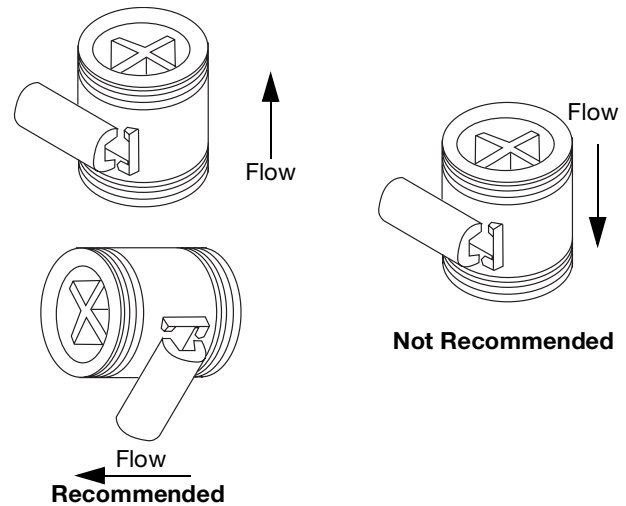

Figure 2

The turbine meter may be mounted in either the horizontal or the vertical position; be certain the pipe will be full of water at all times. The preferred orientation is either up-flow or horizontal direction (Figure 2). **DO NOT** mount the turbine meter vertically with the water flowing down.

Care should be taken to adequately support and align the plumbing in and out of the turbine meter. The turbine meter housing may break if there is too much stress on it. Do not overtighten the turbine meter housing adapter nuts; doing so may damage the threads. The probe will "click" into place when inserted the proper depth into the probe receptacle (Figure 3). Run the turbine meter cable to the controller along the plumbing, using cable ties to secure it. **DO NOT** attempt to pull Hall Effect Cable end through the conduit!

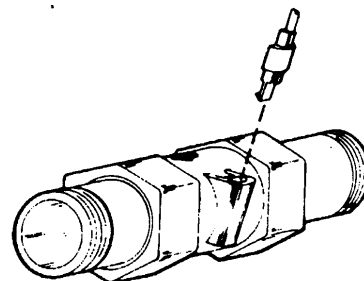

Figure 3

Electrical Requirements

A dedicated, fused power supply is required. To avoid unintentional power interruption to the system, be certain the power supply is not controlled by a switch.

The 480QC is capable of handling the following current/voltage levels: 10 amps/24VAC, 3 amps/100VAC, 3 amps/120VAC or 1.5 amps/230VAC. The NEMA 4 enclosure requires the use of watertight conduit and connectors. Local electrical codes must be followed.

Note: A 24VAC, 50 VA (volt-amp) plug-in transformer is available from Pentair Water for North American applications where **only** controller motors and/or solenoids are powered. However, when using the 480QC to operate 24VAC gear motors, which typically draw about 8 amps, a transformer having a 300 VA rating will be required (not available from Pentair Water). Determine the full volt-amp power requirement of the system in order to select an appropriate transformer.

Fuses

Power Distribution Board:

| | | |
|----|-----------------|-----------|
| F1 | 10.0 Amp SloBlo | 5 x 20 mm |
| F2 | 0.25 Amp SloBlo | 5 x 20 mm |

Circuit Board:

| | | |
|-------|---------------------|-----------|
| F1-F6 | 3.0 Amp SloBlo | 5 x 20 mm |
| F1 | Isolation Signal | Tank 1 |
| F2 | Isolation Signal | Tank 2 |
| F3 | Isolation Signal | Tank 3 |
| F4 | Regeneration Signal | Tank 1 |
| F5 | Regeneration Signal | Tank 2 |
| F6 | Regeneration Signal | Tank 3 |

480QC Magnum Cv Series

Installation of 480QC Cables

The QC cable carries the operating voltage and the start regeneration signal voltage from the 480QC to the 952QC controller. It also carries the feedback signal from the 952QC controller to the 480QC. A separate black and red cable carries the feedback signal from the feedback switch to the 952QC controller. The isolation signal from the 952QC controller is available through the yellow and white cable.

After the installation of the water conditioner control valve to the mineral tank has been completed, and the 480QC control has been mounted, proceed with installation of the 952QC controller onto the Magnum Cv control valve.

DO NOT PLUG WALL TRANSFORMER INTO OUTLET UNTIL INSTALLATION IS COMPLETE.

1. Install the 952QC controller on the valve. Reference the **Magnum Cv Installation and Service Guide**.
2. Connect the black wire of the feedback cable to the COMMON and the red wire of the feedback cable to the NORMALLY CLOSED terminals of the valve-mounted feedback switch.
Black = Common
Red = Normally Closed
3. Connect the yellow and white isolation signal wires of each timer to their respective isolation solenoid valves (**D** systems only).
4. Following the tank designations on the bottom of the 480QC enclosure, insert the keyed plug of each 480QC cable into its respective keyed socket; twist the ribbed locking collar of the plug to secure the connector.
5. For 24VAC systems, connect the input power cable to the transformer secondary terminals and plug the wall mount transformer into an outlet that is not controlled by a switch.
6. Continue the installation of the 480QC system in the following order:
 - **Select a Multiple Tank operating System**
 - **How to Program**
 - **Connect the Battery Back-Up**

Autotrol Valves

When ordered, the 480QC cables are pre-wired to Autotrol control valves at the factory. After the control valves have been installed on the conditioner tanks, insert the keyed plug of the 480QC cable into its respective keyed socket; twist the ribbed locking collar of the plug to secure the connector.

Note: If the system is to be operated at 24VAC, refer to the note under **Electrical Requirements** regarding 24VAC operation.

Non-Autotrol Valve

Follow Table 1, page 5: **Wire Color/Function** under **480 QUICK CONNECT CABLES** to properly terminate the cable at the water conditioner control valves.

Note: Connect the black wire of the feedback cable to the **COMMON** terminal of the feedback switch; the red feedback wire is to be connected to the terminal of the feedback switch that is **open** when the control valve is in the service position.

After the control valves have been installed on the conditioner tanks, insert the keyed plug of the 480QC cable into its respective keyed sockets; twist the ribbed locking collar of the plug to secure the connector.

Note: If the system is to be operated at 24VAC, refer to the note under **Electrical Requirements** regarding 24VAC operation.

Line Voltage Connections

NEMA 4 Enclosure

NEMA 4 units are not supplied with a power cord.

1. Remove the enclosure cover by unscrewing the four large captive fasteners.
2. Connect GROUND, HOT and NEUTRAL of the power source to the 480QC terminals as shown in Figure 4.

Note: Do not attach the battery back-up connector to its terminal pins until instructed to do so after programming the 480QC.

Continue with the installation of the 480QC system in the following order:

- **How to Program**
- **Connect the Battery Back Up**

Select a Multiple Tank Operating System

Note: The system selector switches have been factory set according to the type of operating system (D2, E2, D3 or E3) that was ordered. **If the operating system requires changing, proceed as follows:**

1. Disconnect electrical power to the 480QC.
2. Disconnect the battery backup from terminal J1C (see Figure 5).
3. To view the circuit boards, remove the four nylon screws. The system selector switches are located at the lower left corner of the top (display) circuit board, see Figure 6.

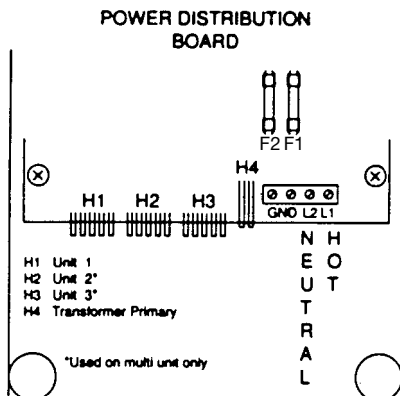

Figure 4

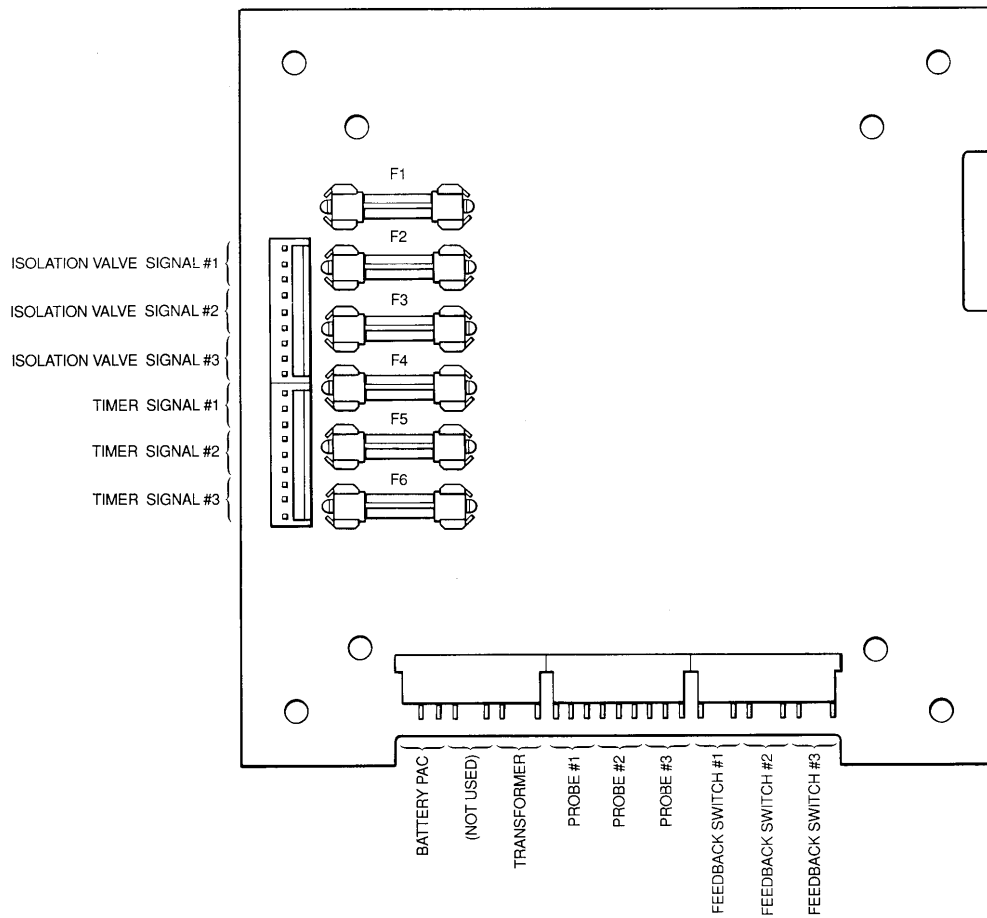

Figure 5

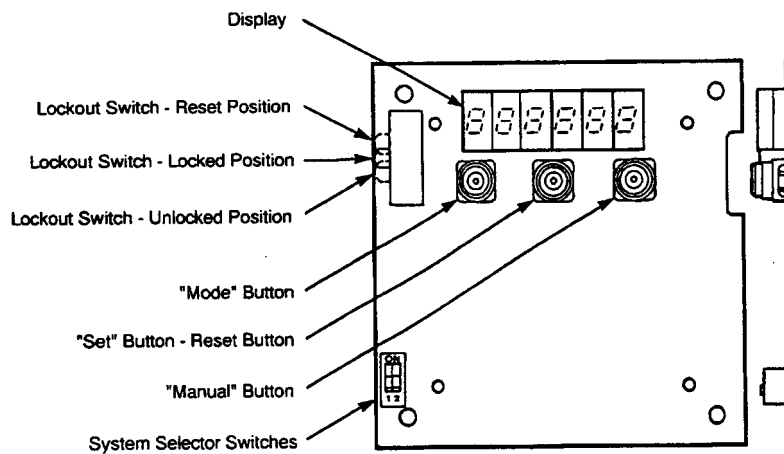

Figure 6

4. Select one of the following systems:

System D2

Alternating Twin System. One tank is “on line” and the other tank is “off line”. When a tank completes a regeneration, it is placed in standby.

System E2

Parallel Twin System. Both tanks are “on line”. The control utilizes a “look ahead” feature which averages peak flow rates at 15-minute intervals over the last seven days to determine a “two-hour reserve”. A comparison of both tanks’ remaining capacity is continuously made and, if it is possible that a tank could become exhausted (based on the two-hour reserve) while the other tank was in regeneration, a regeneration of the most exhausted tank is started early. This is done to insure that a tank does not send hard water to service.

System D3

Alternating Triple System. Two tanks are “on line” and one tank is “off line”. When a tank completes a regeneration it is placed in standby. The control utilizes a “look ahead” feature which averages peak flow rates at 15-minute intervals over the last seven days to determine a “two-hour reserve”. A comparison of both tanks remaining capacity is continuously made and, if it is possible that a tank could become exhausted (based on the two-hour reserve) while the other tank was in regeneration, a regeneration of the most exhausted tank is started early. This is done to insure that a tank does not send hard water to service.

System E3

Parallel Triple System. Three tanks are “on line” except when one tank is in regeneration. When a tank completes a regeneration it goes back “on line”. The control utilizes a “look ahead” feature which averages peak flow rates at 15-minute intervals over the last seven days to determine a “four-hour reserve”. A comparison of all three tanks remaining capacity is continuously made and, if it is possible that a tank could become exhausted (based on the four-hour reserve) while another tank was in regeneration, a regeneration of the most exhausted tank is started early. This is done to insure that a tank does not send hard water to service.

5. Set system selector switches as shown in Figure 7.

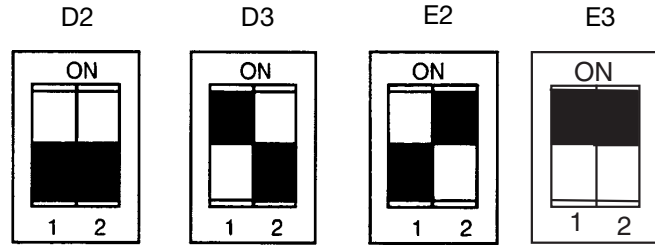

Figure 7

6. Reconnect electrical power to the unit.
7. Reconnect the battery back up.
8. Reinstall the faceplate.

How To Program

- Figure 8 illustrates the faceplate of the 480QC control. Be sure the system selector switches are properly set. It is necessary to remove the faceplate in order to view the system switches located at the lower left corner of the top circuit board.

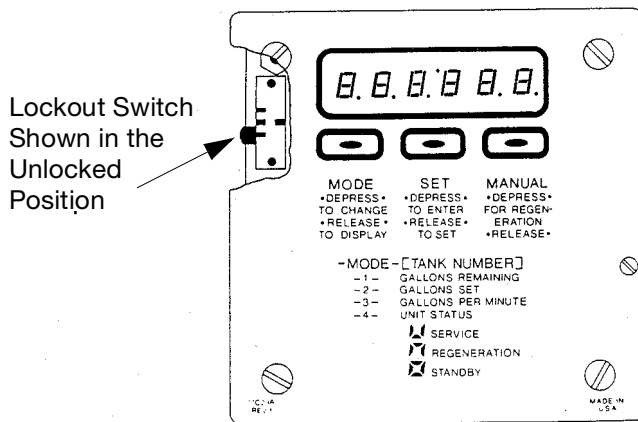

Figure 8

Check that the Lockout Switch is in the **UNLOCKED** (down) position. When power is first connected to the control, the display will show six eights (Figure 8). If the six eights do not appear, or the display shows something other than the six eights, refer to **Resetting the 480QC**.

In the following example, a D3 system is programmed.

- Depress the **MODE** button. The display shows

Then this

Then this

When the display shows , release the **MODE** button.

- The control is now in Mode 2, Tank [1] where the volumetric capacity of the unit is displayed. The value may be changed if the Lockout Switch is in the **UNLOCKED** position. For this example, the calculated capacity is 45,000 gallons. The numbers are entered one at a time, from right to left. Depressing the **SET** button will roll the numbers "0" through "9" in the first position.

Releasing the **SET** button holds the number selected and shifts to the next position. This occurs for each of the six digits.

To enter 45,000 gallons, proceed as follows:

The display shows . DO NOT change the "0".

The display shows . Again, depress the **SET** button and release.

The display shows . Again, depress the **SET** button and release.

The display shows . To change "0" to "5", depress the **SET** button and keep it depressed until "5" appears in the fourth position , then release.

The display shows . To change "0" to "4", depress the **SET** button and keep it depressed until "4" appears in the fifth position , then release.

The display shows . The capacity must now be entered into the microprocessor.

Depress the **MODE** button until the display shows , then release.

The display shows . The calculated capacity of the unit is now programmed into the microprocessor.

- Depress the **MODE** button until the display shows , then release.

The control is in Mode 2, Tank [2] where the volumetric capacity of Tank 2 is displayed. When Mode 2, [1] is programmed, the microprocessor will assign the same capacity to Tank 2. If the capacity of Tank 2 is different than the capacity of Tank 1, the value can be changed by using the procedure described in Step 3.

Note, however, the capacity will not be changed in the microprocessor until Tank 2 regenerates.

The display shows .

- Depress the **MODE** button until the display shows , then release.

The control is now in Mode 2, Tank [3] where the volumetric capacity of Tank 3 is displayed. When

Mode 2, [1] is programmed, the microprocessor will assign the same capacity to Tank 3. If the capacity of Tank 3 is different than the capacity of Tank 1, the value can be changed by using the procedure described in Step 3.

Note, however, the capacity will not be changed in the microprocessor until Tank 3 regenerates.

The display shows .

6. Depress the **MODE** button until the display shows , then release.

Control is now in Mode 3, Tank [1] where the flow rate of Tank 1 is displayed. The rate shown is in gallons per minute and is updated every five seconds. In a D2 or D3 system, when power is connected to the control, Tank 1 is placed in the standby position; there will not be a flow rate displayed.

The display shows .

Depress the **MODE** button until the display shows , then release.

The control is now in Mode 3, Tank [2] where the flow rate of Tank 2 is displayed. The rate shown is in gallons per minute and is updated every five seconds. For this example, the flow rate is 25 gpm.

The display shows .

Depress the **MODE** button until the display shows , then release.

The control is now in Mode 3, Tank [3] where the flow rate of Tank 3 is displayed. The rate shown is in gallons per minute and is updated every five seconds. For this example water is flowing at 25 gpm.

The display shows .

7. Depress the **MODE** button until the display shows , then release.

The control is now in Mode 4 where the status of each tank is displayed. When power is connected to the control, the microprocessor will place Tank 1 in Standby, and Tanks 2 and 3 in Service. (For an E2 or E3 system, all tanks are placed in Service.)

The Display shows .

8. Depress the **MODE** button until the display shows . The control is in Mode 1, Tank [1] where the remaining capacity of Tank 1 is

displayed. When the volumetric capacity of the tanks is entered into the microprocessor (see step 3), that number is transferred into Mode 1, Tank [1] and, as the turbine counts the gallons, the display is updated every five seconds, showing the capacity remaining.

Because Tank 1 is in Standby, all of its volumetric capacity remains.

The display shows .

Depress the **MODE** button until the display shows .

The control is now in Mode 1, Tank [2] where the remaining capacity of Tank 2 is displayed. When the volumetric capacity of the tanks is entered into the microprocessor (see step 3), that number is transferred into mode 1, Tank [2] and, as the turbine counts the gallons, the display is updated every five seconds, showing capacity remaining.

The display shows , the actual gallons of capacity remaining.

Depress the **MODE** button until the display shows , then release.

The control is now in Mode 1, Tank [3] where the remaining capacity of Tank 3 is displayed. When the volumetric capacity of the tanks is entered into the microprocessor (see step 3), that number is transferred into Mode 1, Tank [3] and, as the turbine counts the gallons, the display is updated every five seconds, showing the capacity remaining.

The display shows , the actual gallons of capacity remaining.

The control is now programmed. To prevent tampering with the programmed values, move the Lockout Switch to the **LOCKED** (center) position, Figure 9. The Lockout Switch disables the **SET** button. It is still possible to view each of the modes, but the programmed values cannot be changed.

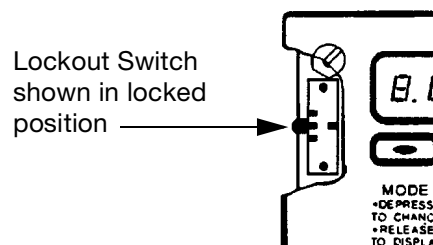

Connecting the Battery Back Up

1. Attach the red connector to the connector pins J1C on the lower (power) board, see Figure 5.

Note: The batteries are shipped discharged. After 48 hours of operation, the batteries will be fully charged.

2. If previously removed, replace the faceplate, securing it with the four nylon screws.

Final Checkout

1. Open supply water to provide flow through the system of at least three gpm. The following should be displayed in each mode:

Mode Display

- 1- The volumetric capacity remaining for each tank (gallons or cubic meters) is updated every five seconds, counting down from the value set in Mode 2. To display the capacity remaining for Tank 1, press the MODE button until -1-[] appears, then release. Repeat procedure for remaining tanks.
- 2- The volumetric capacity of each tank after a regeneration. (Total gals./regeneration.)
- 3- The average flow rate (gallons per minute or cubic meters per hour) for each five-second period for each tank.
- 4- Status of each tank. On power-up, the status, depending on the selected operating system, will be as follows:

D/2: 10 20

D/3: 10 20 30

E/2: 10 20

E/3: 10 20 30

Note: “ □ ” means the tank is in the standby mode (bottom four segments).

“ U ” means the tank is in the service position (bottom three segments).

“ ▾ ” means the tank is in regeneration (inverted u).

Note: The volumetric capacity must be entered into MODE 2 for the controller to function.

2. The manual bypass valve must be closed.
3. The manual inlet and outlet valves must be open.
4. Test for soft water from a convenient soft water tap.
5. The brine line shut-off valve must be open.
6. The drain line flow control must be installed and the drain line unobstructed.
7. The electrical power to the controller must be on and not be controlled by a switch.
8. Check cycle times for backwash, brine/rinse and fast rinse.

Manual Regeneration

Tanks may be manually regenerated through the 480QC at any time. Up to three tanks can be regenerated in any sequence. The microprocessor will remember which tanks are to be regenerated, in what sequence, and to lock out the tanks in service so that one tank, and only one tank, can be regenerated at a time.

In this example a D3 system will be regenerated; Tank 1 first, Tank 2 second, and Tank 3 last.

Move the Lockout Switch to UNLOCKED (Figure 8).

Depress the **MODE** button until the display shows , then release.

The display will show .

To regenerate Tank 1:

Depress the **SET** button, then release. The display will show .

Depress the **MANUAL** button, hold for 3 seconds, then release.

To regenerate Tank 2:

Depress the **SET** button, then release. The display will show .

Depress the **MANUAL** button, hold for 3 seconds, then release.

To regenerate Tank 3:

Depress the **SET** button, then release. The display will show .

Depress the **MANUAL** button, hold for 3 seconds, then release.

To enter the sequence into the microprocessor:

Depress the **MODE** button until the display shows , then release.

The display will now show . Tank 1 is in Regeneration (" R ") and Tanks 2 and 3 are in Service (" U ").

Be sure to move the lockout switch back to LOCKED after the regeneration begins.

When Tank 2 completes its regeneration, the display will show . Tank 3 is in Regeneration (" R ") and Tanks 1 and 2 are in Service (" U ").

When Tank 3 completes its regeneration, the display will show . Tanks 1 and 2 are in Service (" U ") and Tank 3 is in Standby (" S ").

When a tank is in Regeneration or Standby, it does not have any water flowing to service so the flow rate (shown in Mode 3) will be zero.

When a tank in a D2 or D3 system has completed its regeneration, it is placed in Standby. This is shown by a " S " after its tank number in Mode 4. Systems E2 and E3 do not have Standby modes, they return to service after regeneration.

When a tank in any system has completed a regeneration, its capacity remaining will be automatically set to the value originally programmed in Mode 2.

Resetting the 480QC

The 480 control can be reset by moving the lockout switch to RESET (up) (Figure 10), pressing the SET button, then releasing. When the control is reset, the display will show six eights. Any information stored in the microprocessor will be erased. The 480 control must now be reprogrammed. Refer to **How To Program** (page 12).

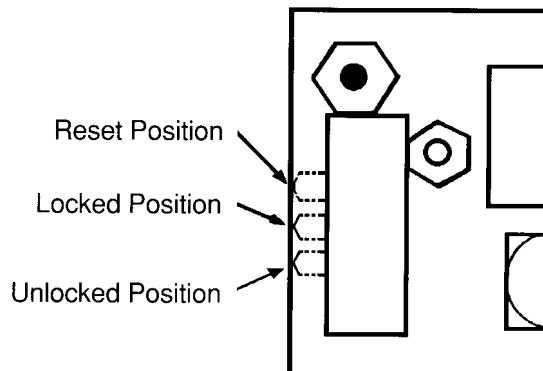

Figure 9

Specifications

| | |
|-------------------------------------|--|
| Input Voltage Ratings (+10%, - 15%) | 24VAC, 100VAC, 120VAC, 230VAC |
| Frequency | 50/60 Hz |
| Phase | Single |
| Power Draw | 240 Volt-Amps maximum (includes external solenoids and/or valve drive motors powered through 480QC) |
| Regeneration Signal | 200 Volt-Amp maximum draw |
| Feedback Circuit | 5VDC, dry contact, normally open in service |
| Turbine Sizes | 1-inch (25mm) and 2-inch (51 mm) |
| Materials | Housing: Noryl; Turbine: Polypropylene |
| Bearings | 1-inch (25 mm) Turbine - Polymide; 2-inch (51 mm) Turbine-Carbon Graphite |
| Maximum Flow | 1-inch (25 mm) - 40 gpm (9.1 M ³ /H); 2-inch (51 mm) - 250 gpm (57 M ³ /H) |
| Minimum Flow | 1-inch (25 mm) - 0.25 gpm (0.06 M ³ /H); 2-inch (51 mm) - 2 gpm (0.45 M ³ /H) |
| Accuracy | ±3% of full scale |
| Pressure Drop | 2-inch (51 mm) 2.5 psi (0.17 bar) at 150 gpm (34 M ³ /H) 1-inch (25 mm) 1.5 psi (0.10 bar) at 30 gpm (7 M ³ /H) |
| Maximum Temperature | 120 °F (49 °C) |
| Turbine Rotation Detection | Solid-state Hall effect switch activated by magnet attached to turbine |
| Turbine Connections | 1-inch (25 mm) or 2-inch (51 mm) brass NPT or BSP pipe adaptors; 1-inch (25 mm) or 2-inch (51 mm) PVC pipe adaptors |

Turbine

1-inch (25 mm) Turbine

1-inch - 11 1/2 NPT or 1-inch - 11 BSPT

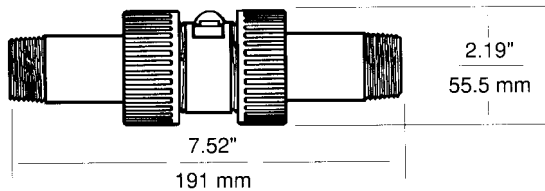

Pressure Drop Curves

1-inch (25 mm) Turbine

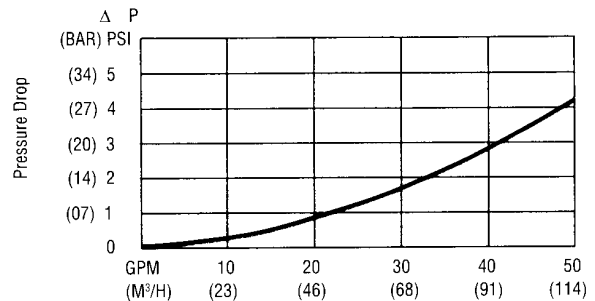

2-inch (51 mm) Turbine

2-inch - 11 1/2 NPT or 2-inch - 11 BSPT

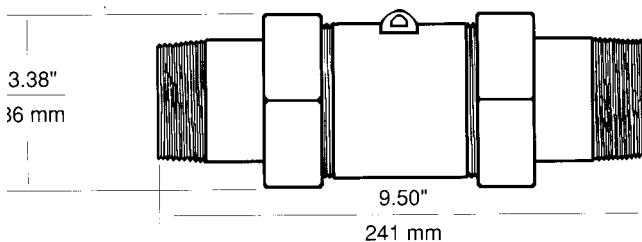

2-inch (51 mm) Turbine

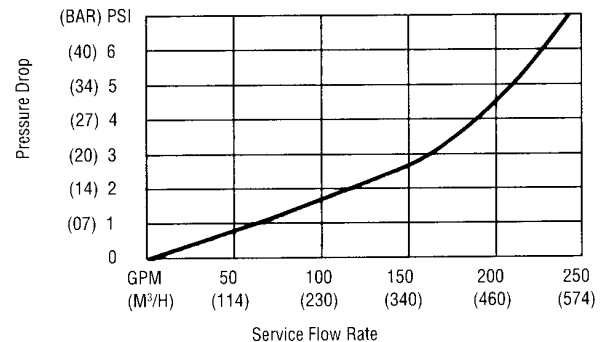

Dimensions

Nema 4 Outline and Mounting Dimensions

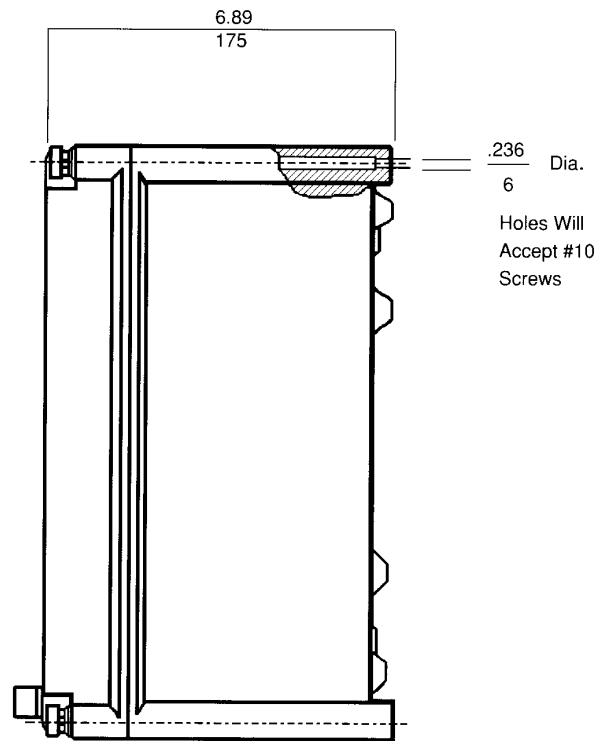
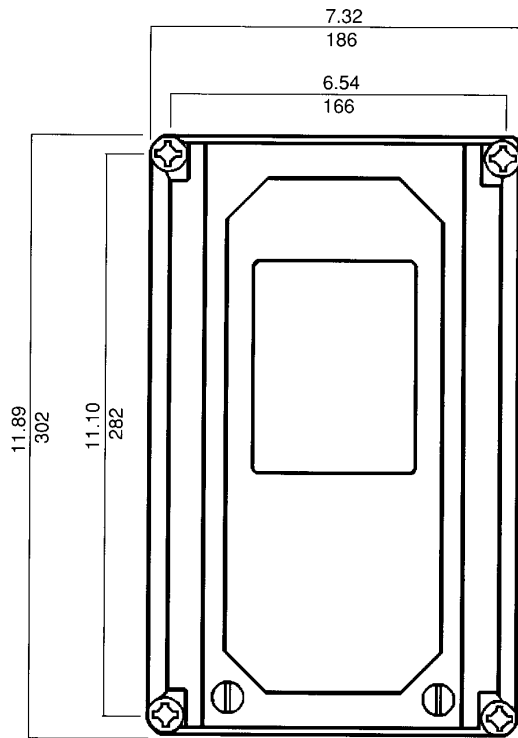

Systems Drawings

Multiple Tank System D/2 Flow Diagram

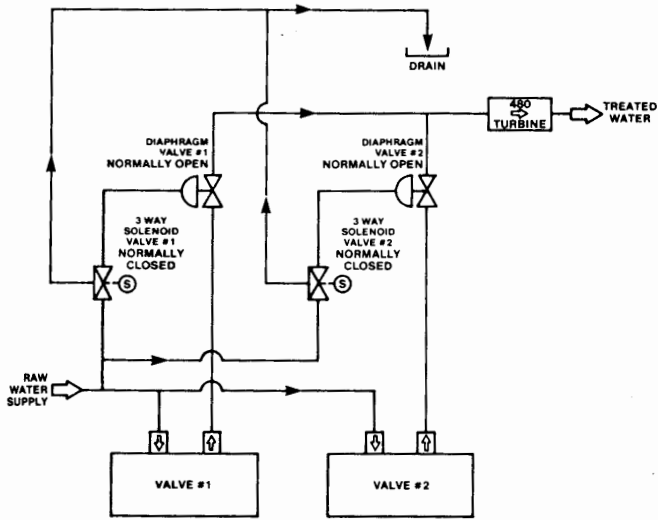

Multiple Tank System E/2 Flow Diagram

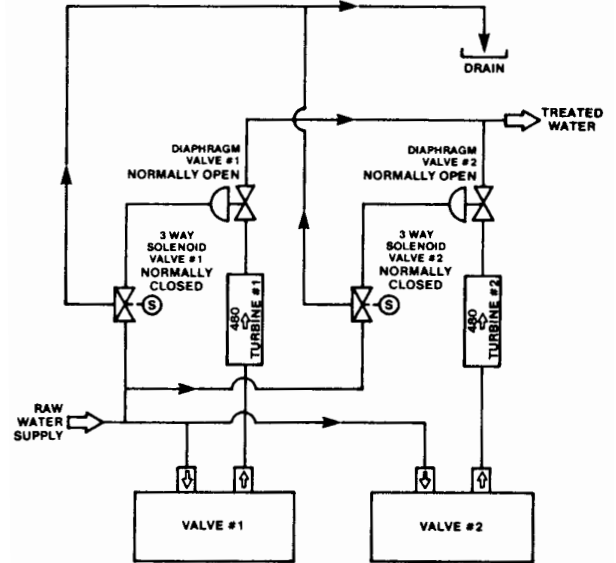

Multiple Tank System D/3 and E/3 Flow Diagram

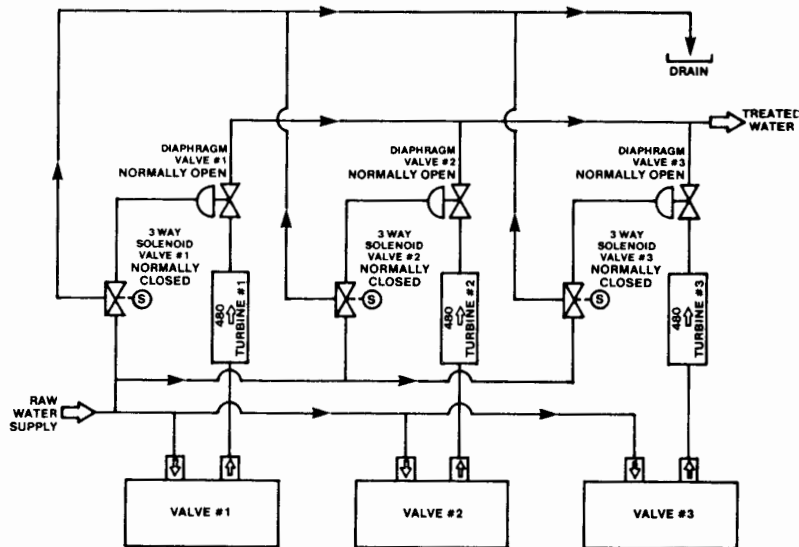

Service and Troubleshooting Guide

Theory of Operation

The 480QC control is very simple and uncomplicated. Once the system is installed and programmed, it needs only two pieces of information (inputs) per unit; flow data, gathered from the turbines via the turbine probe, and tank status, gathered from the feedback switch via the feedback cables. The turbines, located in the service outlet water stream, provide magnetic pulses that are detected by a Hall effect device in the turbine probe. The Hall effect device sends electrical pulses via the cable to the microprocessor in the 480QC control. The microprocessor converts the pulses to flow rate and water usage equivalents. The flow rate for an individual tank is displayed in Mode 3 and is updated every five seconds. The water usage is deducted from the capacity remaining for that tank and is displayed in Mode 1. Water usage information is also used in the software program contained in the 480QC control. A feedback switch, operated by a cam on a valve or inside a stager, provides a signal to the 480QC control indicating when a tank is regenerating. The 480QC control software provides a lock-out provision that will not allow regeneration of more than one tank at a time. When a regeneration is required, either by manual initiation through the 480QC control or because of water usage, a line voltage start regeneration signal and a line voltage isolation signal (lock-out signal) are sent to the water conditioner control valve. The start regeneration signal will last a maximum of twelve minutes and is used to start a controller motor or energize a solenoid to begin the regeneration sequence. The isolation signal is present throughout the regeneration sequence and is generally used to energize a solenoid actuated diaphragm valve on the service outlet of the tank, removing the tank from service during regeneration. When the 480QC is programmed as a "D" operating system the isolation signal remains active after the regeneration sequence is complete, keeping the newly regenerated tank in standby.

480QC Input/Output Sockets

A bottom view of a 480QC is pictured in Figure 10, illustrating the socket locations for each tank of a triple-tank system. The pin layout for each of the three sockets is the same.

480QC Bottom View

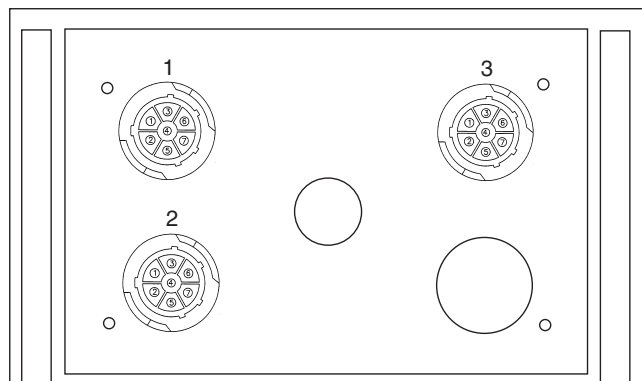

Figure 10

Table 2 identifies the outputs and feedback circuit input for the socket.

Table-2

| Pin | Function |
|-----|-----------------------------|
| #1 | Neutral |
| #2 | Start Regeneration Signal |
| #3 | Hot |
| #4 | Ground |
| #5 | Isolation (lock-out) Signal |
| #6 | Feedback |
| #7 | Feedback |

Certain troubleshooting procedures may require checking for voltage outputs at various pins of the 480QC sockets on the bottom of the enclosure. Twist the ribbed locking collar of the 480QC cable connector and disconnect the cable from the socket to gain access to the pins. Figure 11 shows the voltages that should be present across various sets of pins.

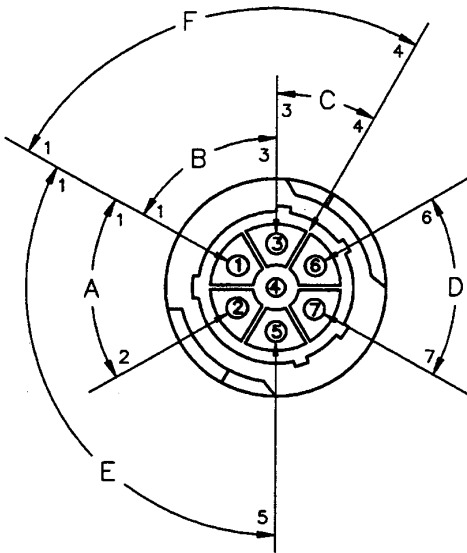

Figure 11

The following provides information to assist in troubleshooting components of the system. Pay close attention to whether you should be testing for **AC** or **DC** voltage.

Note: Use extreme caution when testing with power to units.

1. At all times and on all systems

Check across pins 1 and 3 [B] (Neutral and Hot) for the presence of supply voltage; 24VAC, 100VAC, 120VAC or 230VAC.

Check across pins 1 and 4 [F] (Neutral and Ground) for less than 1VAC.

Check across pins 3 and 4 [C] (Hot and Ground) for the presence of supply voltage; 24VAC, 100VAC, 120VAC or 230VAC.

Check across pins 6 and 7 [D] (Feedback circuit) for the presence of 5VDC.

2. On E2 and E3 systems when Mode 4 indicates all tanks in service

At all sockets:

Check across pins 1 and 2 [A] (Neutral and Start Regeneration Signal) for less than 3VAC.

Check across pins 1 and 5 [E] (Neutral and Isolation Signal) for less than 3VAC.

3. On E2 or E3 systems when Mode 4 indicates one tank is regenerating

At the socket for the tank in regeneration:

Check across pins 1 and 2 [A] (Neutral and Start Regeneration Signal) for supply voltage lasting for 12 minutes.

Check across pins 1 and 5 [E] (Neutral and Isolation Signal) for line voltage (will last for only 12 minutes with feedback circuit disconnected).

4. On D2 or D3 systems when Mode 4 indicates one tank in standby

At the socket for the tank in standby:

Check across pins 1 and 2 [A] (Neutral and Start Regeneration Signal) for less than 3VAC.

Check across 1 and 3 [B] (Neutral and Hot) for supply voltage.

Check across pins 1 and 5 [E] (Neutral and Isolation Signal) for supply voltage.

The following provides information to assist in troubleshooting components of the system. Pay close attention to whether you should be testing for **AC** or **DC** voltage.

There are certain characteristics of the 480QC control that must be taken into account when attempting to identify a problem. They are:

Feedback Switch Operation

1. Unless the 480QC control initiates a regeneration, the switches are ignored. A manual regeneration initiated at the control valve or stager will not be recognized by the 480QC control.
2. Providing the feedback switches are operating correctly, the 480QC will never cause more than one tank to go into regeneration at a time and will never indicate more than one tank in regeneration while displaying system status in Mode 4.
3. The 480QC will provide the start regeneration signal for a maximum of twelve minutes. If the feedback switch signal, for the tank that the 480QC is sending the regeneration signal to, does not become active by the end of the 12 minute period, the 480QC will stop the regeneration signal, reset the capacity total and consider that the tank has completed a successful regeneration.
4. The start regeneration signal will end 20 seconds after the feedback switch closes. If the feedback switch is closed when the 480QC initiates a regeneration, the start regeneration signal will last for only 20 seconds--not long enough to initiate an impulse control driven regeneration.

Note: Use extreme caution when testing with power to units.

“Look Ahead” Feature in the E-2, E-3 and D-3 Systems

The 480QC control has the ability to establish a theoretical maximum conditioned water usage number, in gallons or cubic meters, for a two-hour and a four-hour period, based on the water usage pattern. The consumption quantity is called the 2-hour “Peak Demand Number” (2-PDN) and the 4-hour “Peak Demand Number” (4-PDN). This allows the 480QC to “look ahead” and place a tank into regeneration before it counts down completely to zero if it appears there may not be enough capacity remaining in the rest of the system to continue providing conditioned water during

regeneration of one of the tanks. This feature allows the 480QC system to operate at maximum efficiency while insuring conditioned water to service.

Operating Information (Modes)

Four operating values may be displayed on the 480QC control.

Mode 1 - Capacity remaining in each tank

Mode 2 - Programmed Capacity of each tank

Mode 3 - Flow Rate through each tank

Mode 4 - Status of each tank; Service, Regeneration or Standby

To **observe** the operating information in any of the modes, press and hold the **MODE** button until the desired mode number and tank number is displayed, then release the button to display the data. The display will remain in the last mode you observed. To **change** the data in Mode 2, refer to **How To Program**.

Service Procedures

When servicing the 480QC control, the first consideration should be whether this is a start-up or if the system has been operational for a period of time. If it is a start-up and there is no apparent damage to the

shipping containers, then the problem more than likely involves something that has moved during shipment or is the result of the installation itself.

| Symptom | Probable Cause | Corrective Action |
|---|--|---|
| 1. No display | <ul style="list-style-type: none"> a. No power to control. b. Battery connector was installed prior to power-up of control. See Note Pg. 8 under line voltage connections. | <ul style="list-style-type: none"> a. Determine reason and correct. b. Disconnect power and battery. Apply power, program unit and connect battery. |
| 2. Cannot program values into Mode 2 | <ul style="list-style-type: none"> a. Slide switch is in locked position. | <ul style="list-style-type: none"> a. See How To Program |
| 3. 888888 continues to appear when number input is attempted. | <ul style="list-style-type: none"> a. Slide switch is in reset position. | <ul style="list-style-type: none"> a. See How To Program |
| 4. 0.0 is displayed in Mode 2. | <ul style="list-style-type: none"> a. System is operating in metric mode. | <ul style="list-style-type: none"> a. Disconnect power and battery. Reconnect power, program unit, reconnect battery. |
| 5. No flow rate indication in Mode 3. | <ul style="list-style-type: none"> a. A tank has been selected in Mode 3 that is in standby ("D" systems only) b. Turbine probe not fully inserted into turbine housing c. Turbine is stalled (on start up, or shortly after is usually caused by either media fines being flushed from the system, solder or Teflon tape getting caught in the turbine rotor). | <ul style="list-style-type: none"> a. Verify proper tank is being displayed. b. Fully insert turbine probe into turbine housing until it is locked in. c. If a spare 1-inch turbine is available, remove the turbine probe from installed turbine and insert into spare turbine. Blow through spare turbine. If flow is indicated at control, disassemble installed turbine and free turbine rotor. If no flow is indicated, verify that the turbine probe connectors are plugged into their proper terminals on the circuit board. |
| 6. Pre-wired Autotrol Control Valve: Control will not initiate regeneration. | <ul style="list-style-type: none"> a. Feedback switch bracket or brackets have moved during shipment. | <ul style="list-style-type: none"> a. Make sure all control valves are in the service position. Check feedback switch on each control valve to verify they are in the proper state (open contacts). Autotrol 172 control valve feedback switch is located on pilot cam assembly bracket and has blue and white wires connected to it. The switch lever should be depressed by the No. 7 pilot valve rocker when control valve is in the service position. The Autotrol 180 or 182 control valve feedback switch is the top switch on the drive motor switch stack. Switch lever should not be depressed when the control valve is in the service position. The Autotrol Magnum Cv Series control valve feedback switch is mounted on the pilot cam assembly top plate. Switch lever should be depressed by the switch cam when the control valve is in the service position. |

| Symptom | Probable Cause | Corrective Action |
|---|--|--|
| <p>7. Non-Autotrol Control Valve: Control will not initiate regeneration or regeneration stops in cycle.</p> | <ul style="list-style-type: none"> a. Feedback switch is wired incorrectly. b. Incorrect signal wiring. c. Hot (black) and/or Neutral (white) are wired incorrectly at the control valve. | <ul style="list-style-type: none"> a. Feedback switch contacts must be open in service for a multiple tank system. b. Red start regeneration wire must be connected to regeneration signal input on the control valve. c. Follow control valve manufacturer's wiring diagram. |
| <p>8. Fuse blows on circuit board when control is connected to line voltage.</p> | <ul style="list-style-type: none"> a. Hot (black) and Neutral (white) are wired reversed at valve or control. | <ul style="list-style-type: none"> a. Follow control valve manufacturer's wiring diagram. |
| <p>9. Fuse blows on circuit board shortly after regeneration is called for.</p> | <ul style="list-style-type: none"> a. Hot (black) and Neutral (white) wires are reversed at valve or control. | <ul style="list-style-type: none"> a. Follow control valve manufacturer's wiring diagram. |
| <p>10. The wrong tank goes into regeneration.</p> | <ul style="list-style-type: none"> a. Cables have been incorrectly attached to 480QC control. | <ul style="list-style-type: none"> a. Correct cable attachment. |

General Malfunctions

Non-Autotrol Control Valves

When servicing the 480QC control, one of the first things that should be done is to view Mode 4, assuming the display is operational. This indicates the system status as the 480QC control believes it to be. Between what Mode 4 indicates and what the true status of the system is, it may be possible to locate the problem and correct it.

Simulated Regeneration Procedures

A useful procedure for troubleshooting the system is a simulated regeneration, verifying the function of the 480QC control. The procedure is as follows:

1. Display Mode 4 and verify that no tank is indicated to be in regeneration.
2. Initiate a manual regeneration through the 480QC on tank #1.
3. Immediately return to Mode 4 and verify that the "U" icon for tank #1 has inverted, indicating regeneration.
4. Watch Mode 4 for 30 seconds to make sure the icon remains inverted.
5. Verify that the controller motor is running or the solenoid/T-bar has activated.
6. If an isolation solenoid operated diaphragm valve is being used, verify that it is active.
7. If everything is operational, manually rotate the control valve through the regeneration cycle, allowing a minimum of 20 seconds between the time the feedback switch becomes active and the control valve returns to service.
8. The icon should return to upright (Service). On "D" systems the icon should be a box (Standby).
9. Repeat for remaining tanks.

| Symptom | Probable Cause | Corrective Action |
|---------------|--|--|
| 1. No display | <ol style="list-style-type: none"> a. No power to control. b. F-1 fuse is blown. c. F-2 fuse is blown. d. Board failure. | <ol style="list-style-type: none"> a. Determine reason and correct. b. This is the main fuse on the Power Distribution Board (PDB). One of the controller motors, solenoids, or other peripherals may have failed. Turn off power or unplug 480QC control. Disconnect QC cables from 480 control and replace F-1 on PDB. Return power to the controller and note if there is a display. Disconnect power, reconnect one of the cables and reconnect power. If display is good, repeat procedure until all of the cables have been reconnected. If display is good, initiate a simulated regeneration for each of the tanks. If initiation of a regeneration causes the fuse to blow, either the controller motor or solenoid has failed on that tank. c. Transformer mounted on bottom of PDB has failed. With power removed from 480QC control, disconnect transformer connectors from the circuit boards (see exploded view parts diagram). Measure the resistance across the primary and the secondary of the transformer. If either measurement shows open or short, replace the transformer. d. Replace boards. |

| Symptom | Probable Cause | Corrective Action |
|---|--|---|
| <p>2. Tanks will regenerate manually through the 480QC but not automatically.</p> | <p>a. Turbine is stalled or turbine probe is inoperable.</p> <p>b. Programmed capacity exceeds system capacity.</p> <p>c. Feedback switch malfunction.</p> | <p>a. See “No flow rate indication in Mode 3”.</p> <p>b. Recalculate volumetric capacity and reprogram Mode 2.</p> <p>c. Disconnect the 480QC cable from the enclosure for the unit that will not regenerate. Using a volt meter set to DC, insert one probe into socket #6 and the other probe into socket #7. The meter should read 5 volts DC. If it is 0 volts, check the wire harness inside the 480QC controller. The blue and white wires that are terminated with a red connector should be connected to the circuit board. Set the volt meter to AC. Insert one probe into socket #1 and the other probe into socket #2. Initiate a simulated regeneration (see Simulated Regeneration Procedures page). Meter should indicate the line voltage to the 480QC control.</p> |
| <p>3. “Stops” in regeneration. (Display continues to indicate Regeneration)</p> | <p>a. Fuse on circuit board blown.</p> <p>b. Feedback switch problem.</p> | <p>a. Disconnect power, remove enclosure cover, remove the circuit board and check F-1 through F-6 in the upper left corner of the power distribution board. If one of the fuses is blown, check the controller or solenoid on the control valve to determine the cause for the short before replacing the fuse and reapplying the power.</p> <p>b. Verify controller and control valve are in service position. With Mode 4 displayed on the control, indicating tank is in regeneration, disconnect the 480QC cable from the enclosure for the tank that is indicated to be in regeneration. If the icon reverts to indicating the service or standby position, the feedback switch is not opening at the end of regeneration. Locate feedback switch on control valve or stager and correct.</p> |

Wiring Diagram

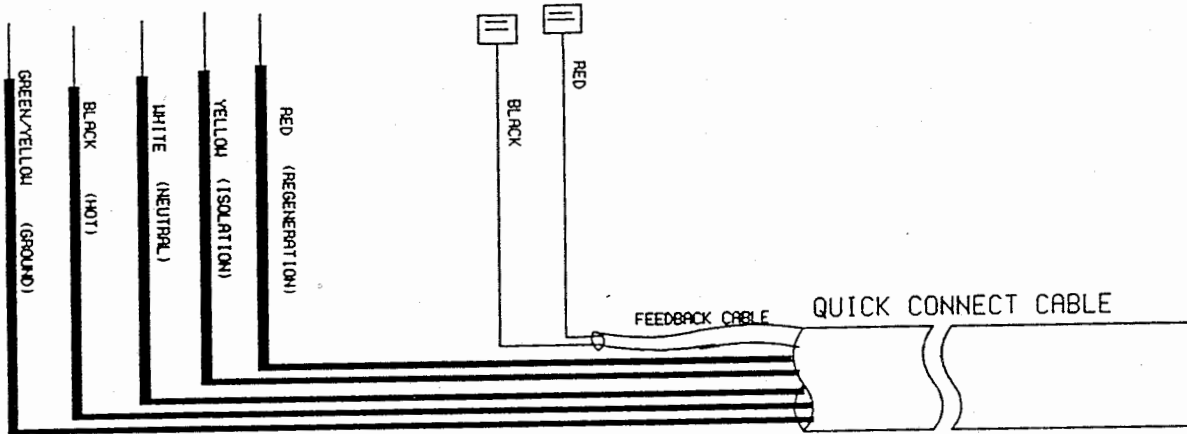

| CABLE LENGTH | PART NUMBER |
|--------------|-------------|
| 7 FEET | 10001752 |
| 14 FEET | 10001753 |
| 21 FEET | 10001754 |

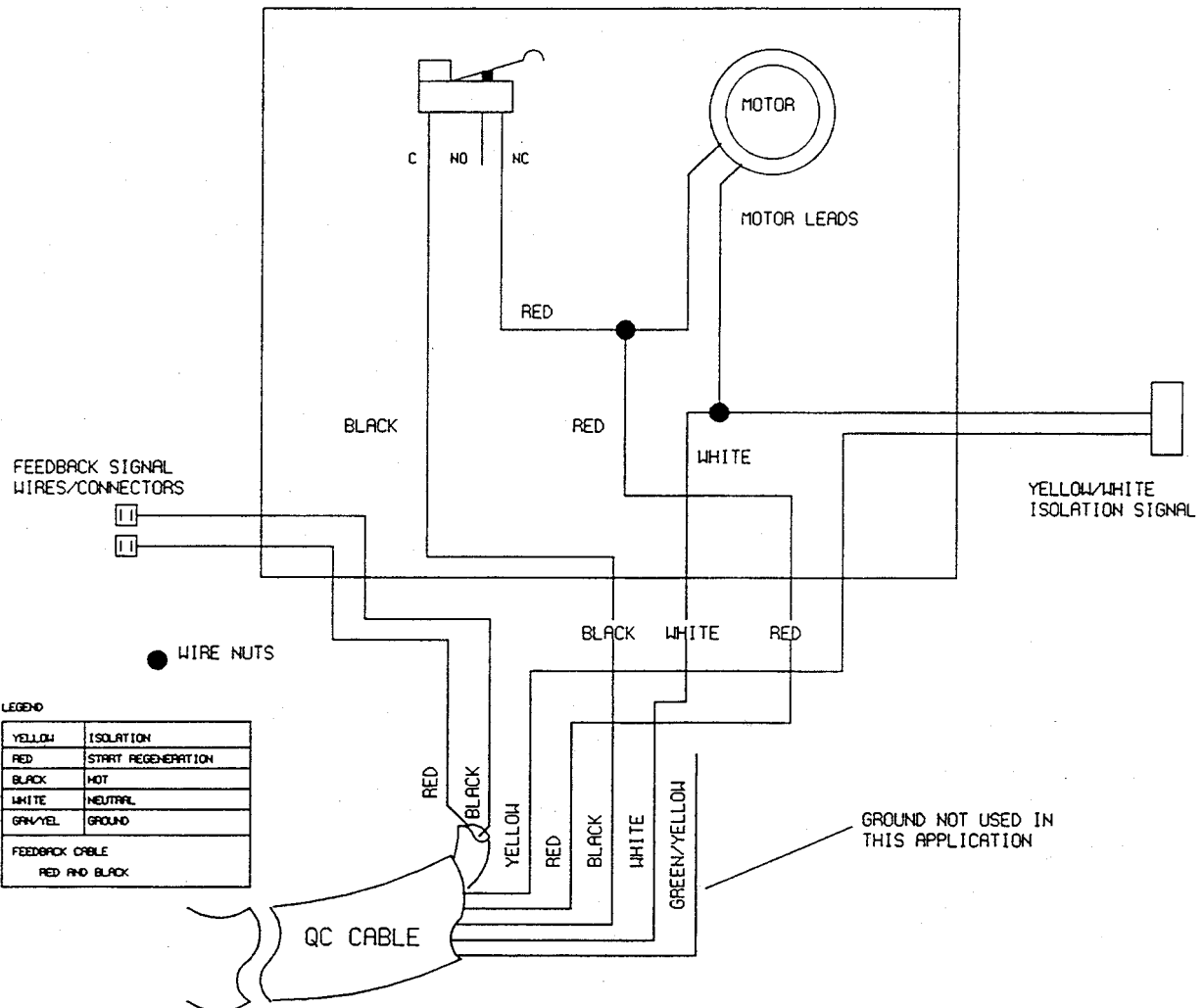

LEGEND

| | |
|----------------|--------------------|
| YELLOW | ISOLATION |
| RED | START REGENERATION |
| BLACK | HOT |
| WHITE | NEUTRAL |
| GRN/YEL | GROUND |
| FEEDBACK CABLE | |
| RED AND BLACK | |

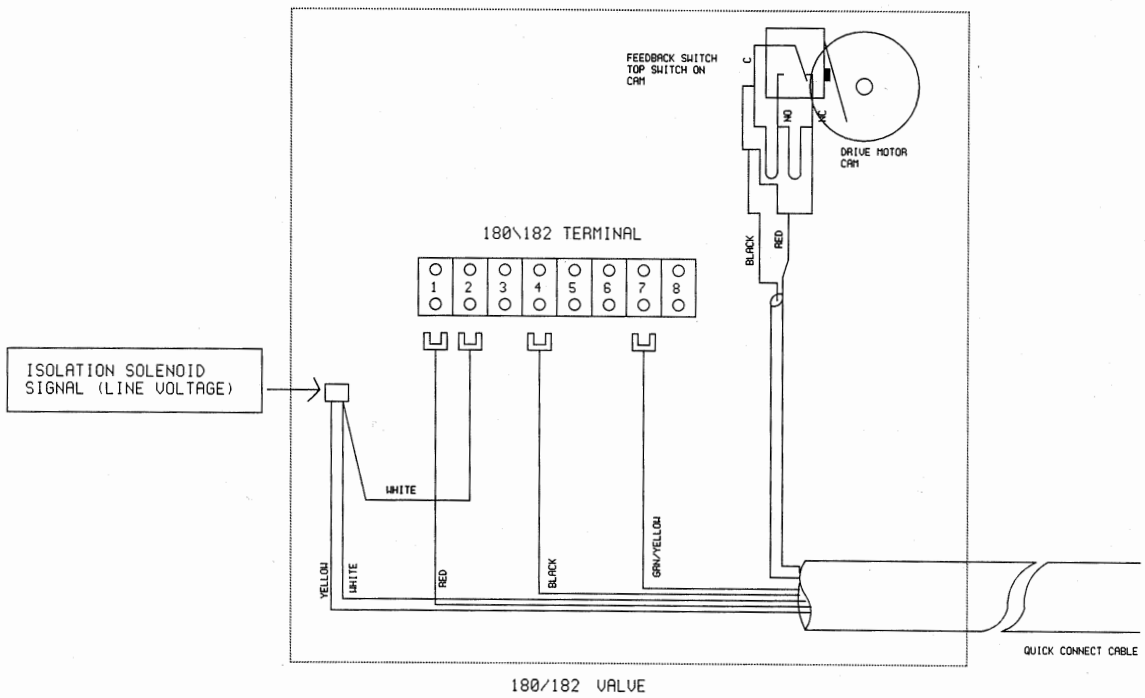
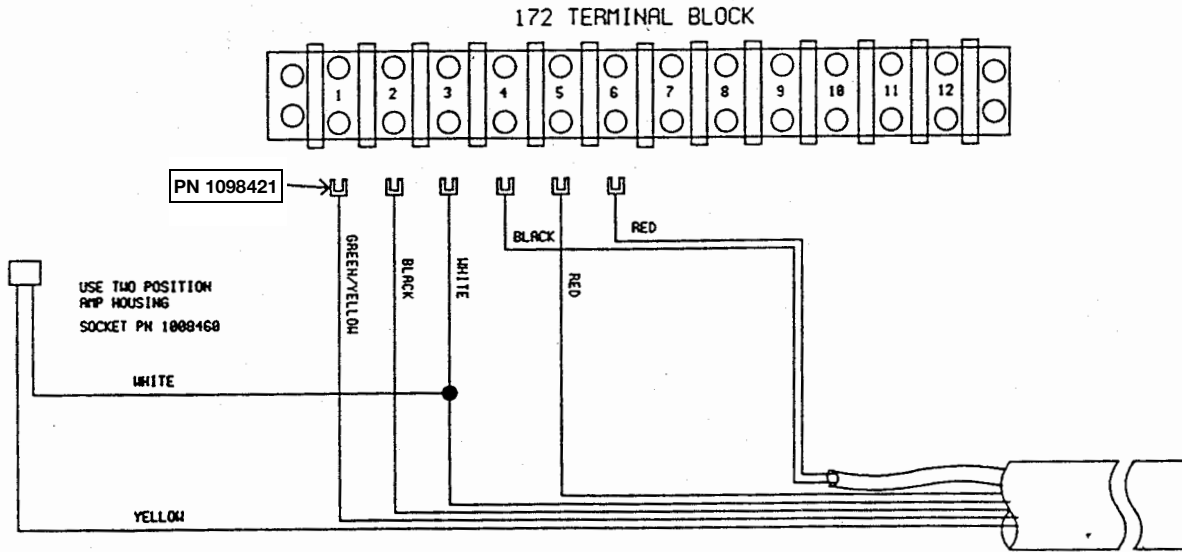

Replacement Parts - NEMA 4

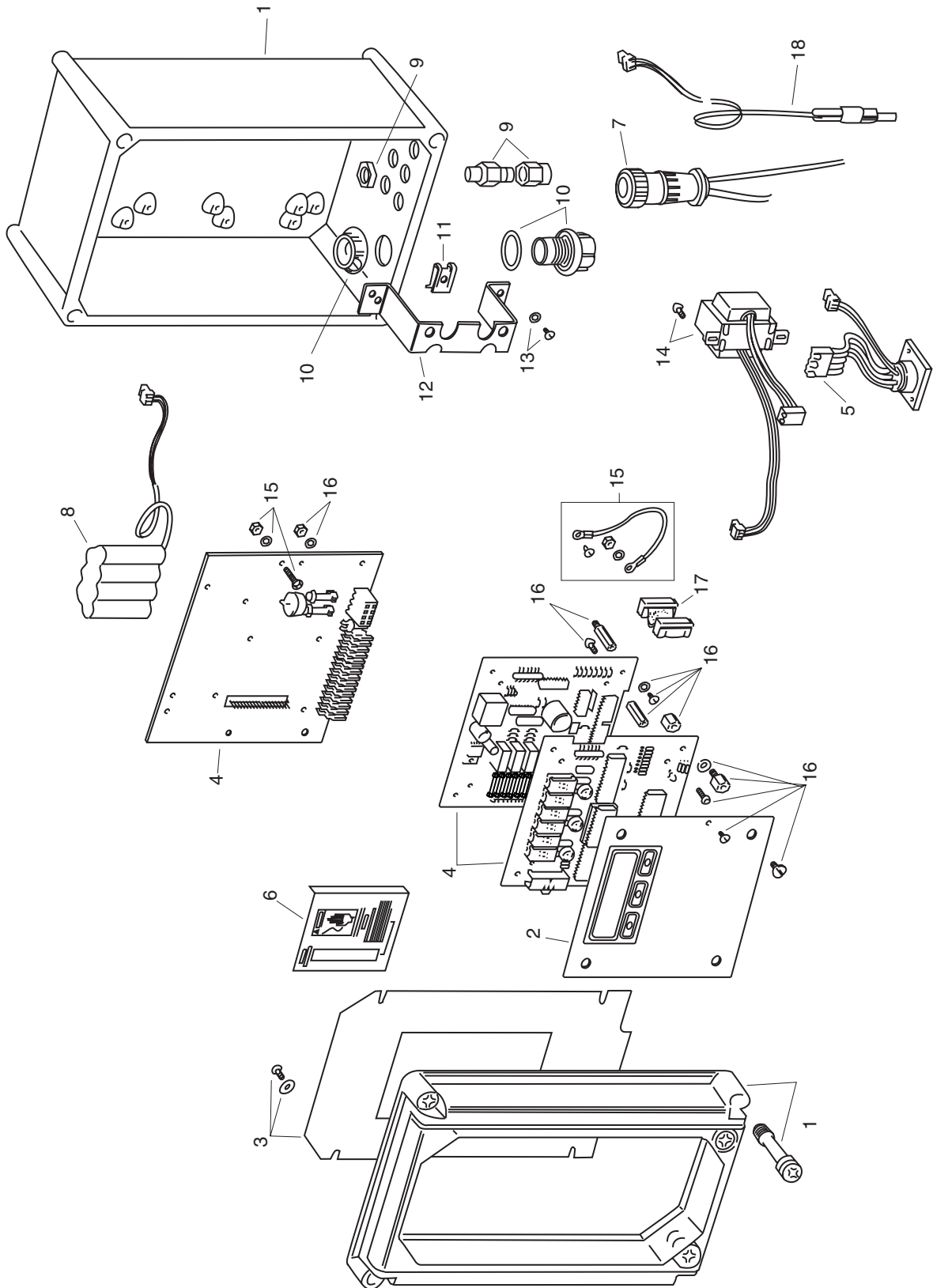

NEMA 4

| Item | Description | Part No. | Item | Description | Part No. |
|------|--|-------------|------|--|----------|
| 1 | NEMA 4 Enclosure | 1032699 | 8 | Back Up Battery Pack w/Mounting Screws | 1034049 |
| 2 | Faceplate Replacement Kit, Standard | 1034051 | 9 | Strain Relief | 1007284 |
| | Faceplate Replacement Kit, Metric | 1034052 | 10 | Conduit Connector | 1007449 |
| 3 | Cover Plate, Painted | 1032106 | 11 | Type U Nut | 1004251 |
| 4 | Circuit Board Assy. for 2" Turbine, Includes Item 5, 6, & 16 | 1033368 | 12 | Plate Support Bracket | 1031598 |
| | Circuit Board Assy. for 1" Turbine, Includes Item 5, 6, & 16 | 1033370 | 13 | Support Bracket Hardware | 1034057 |
| | Circuit Board Assy. for Metric Interface at 60 Hz, for 2" Turbine, Includes Items 5, 6, & 16 | 1033372 | 14 | Transformer, 120V and Mounting Hardware | 1001597 |
| | Circuit Board Assy. for Metric Interface at 60 Hz, for 1" Turbine, Includes Item 5, 6, & 16 | 1033374 | | Transformer, 24V and Mounting Hardware | 1001598 |
| 5 | Internal Cable Wire Assembly | 1034053 | 15 | Ground Strap Assy & Mounting Hardware | 1034043 |
| 6 | Fuse Cover | 400B232-701 | 16 | Circuit Board Mounting Hardware and Standoff Hardware | 1034058 |
| 7 | Quick Connect Cables, Nonterminated | | 17 | Harness Ribbon Cable | 1035312 |
| | 7-feet | 1001836 | 18 | Sensor Assembly | 1033352 |
| | 14-feet | 1001837 | | | |
| | 21-feet | 1001838 | | | |

