

PERFORMANCE BULLETIN

Product Application Service General news from **Pentair Water**

New Tornado Distributor Kit

The new Tornado distributor kit is now available. The Tornado enhances resin cleaning, reduces freeboard requirements, and offers an economical option for cold water applications.

The Tornado can be used with any control valve with 1.05" or 32 mm distributor pilots and can be purchased individually or as an accessory item in box quantities of 24 (Part Number 61100). The slot size is .007 - .009 and will accommodate fine mesh resin. The material is made of ABS plastic for creating easy solvent connections. Each component of the Tornado is in compliance with NSF Standard 61. Enclosed on the 2nd page is the installation sheet.

As always, thank you for using Fleck controls.

Sincerely,

Pentair Water, Inc.

Elizabeth Beasley

Elizabeth Beasley

Technical Communications



61100 INSTALLATION INSTRUCTIONS

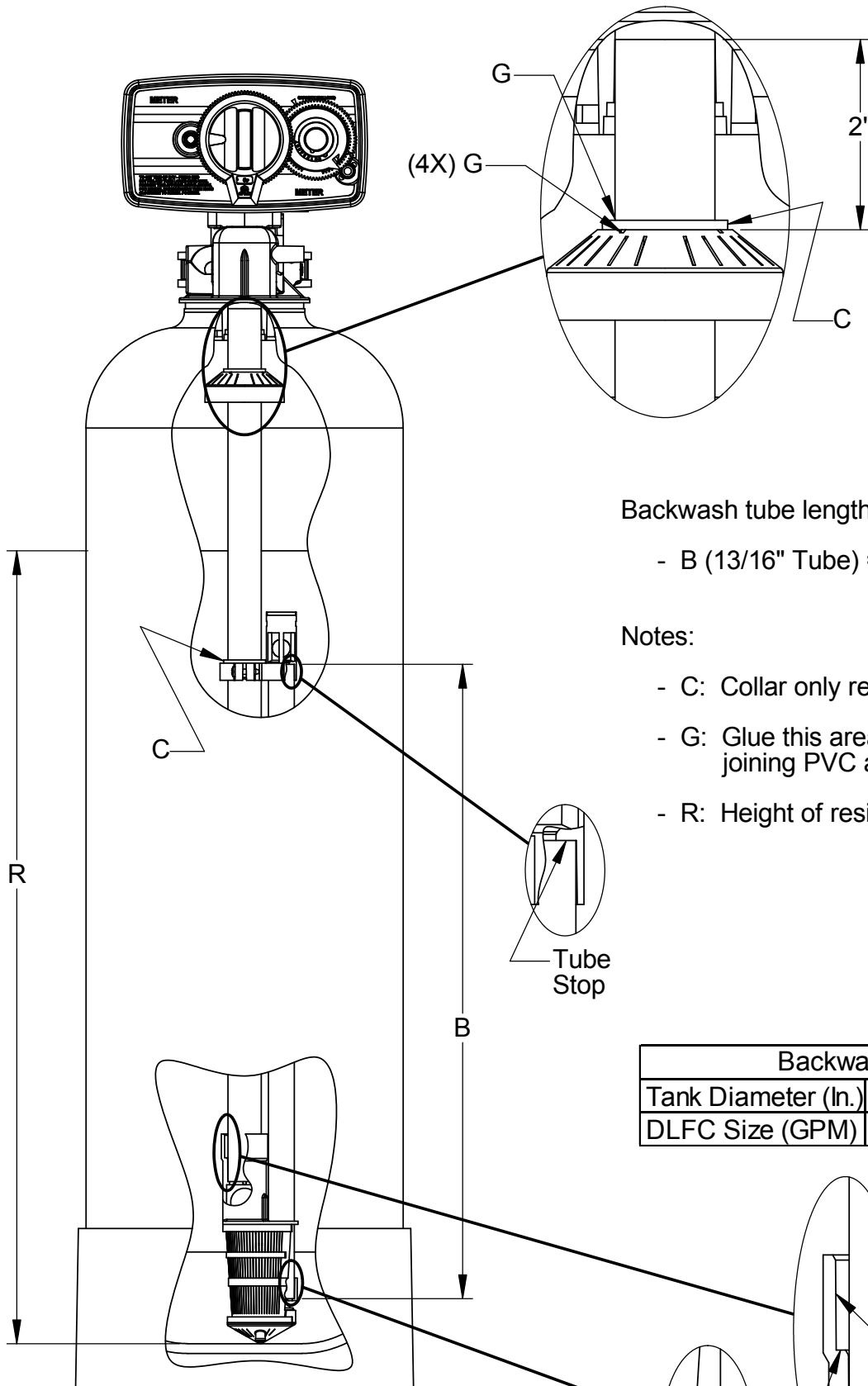

Backwash tube length (B):

- B (13/16" Tube) = R - (7")

Notes:

- C: Collar only required for 1.05" distributor.
- G: Glue this area with a glue suitable for joining PVC and ABS materials.
- R: Height of resin bed from bottom of tank.

Backwash Control Table

Tank Diameter (In.)	6	7	8	9	10	12
DLFC Size (GPM)	1.5	2	2.4	3	4	5

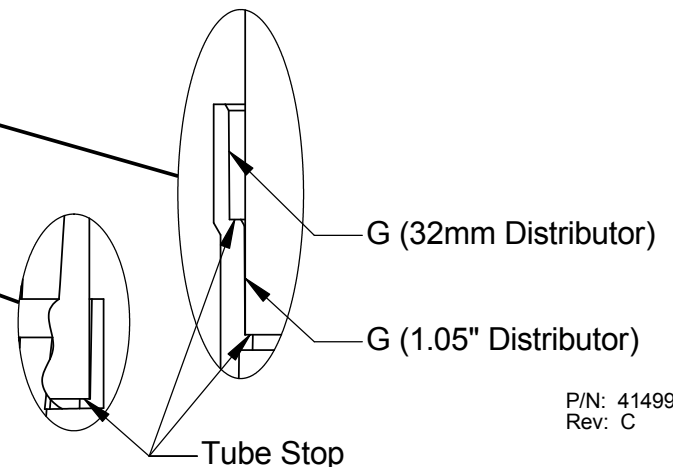

CAUTION

- Minimum water temperature 34° F.
- Maximum water temperature 110° F.