

A FLECK PERFORMANCE BULLETIN

Product Application Service General news from Fleck Controls

September 27, 1991

3900 Soft Water Regeneration

The 3900 control is now available with soft water regeneration. It is recommended that when using the soft water regeneration option, it is ordered with the control. In the event of having to modify a unit, it will be necessary to drill two holes in the lower casting. If you have a 3900 control, which needs the soft water regeneration modification, the next page will show how to modify.

As always, thank you for using Fleck Controls.

Sincerely,

Fleck Controls Inc.
Technical Product Support

3900 Conversion for Soft Water Regeneration

1. Remove upper and lower powerheads.
2. Remove 2-screws (16042), remove the upper valve body (15114) from the lower valve body (16067).
3. Remove coupling (16074).

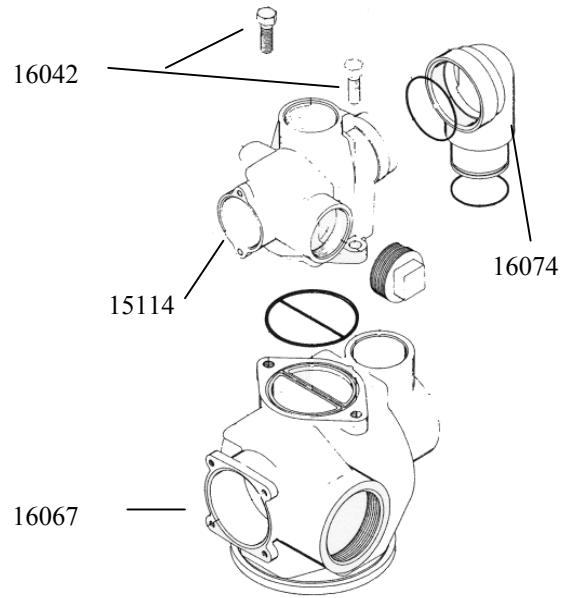

4. Drill size 0.257 (Letter "F")
5. .45" from top of valve body
6. Before drilling hole, install 17453 sleeve, grease 16077 o-ring, then slide in 17454 plug. This will stop shavings from entering the valve body.

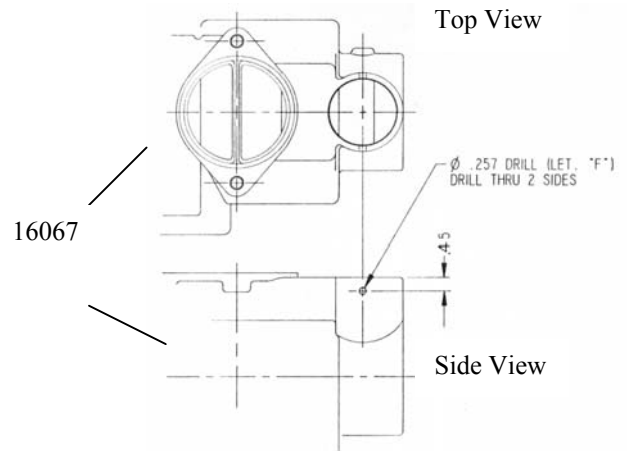

7. Drill holes thru 2 sides of the lower valve body (16067).
8. Insert 17452 shaft thru the drilled holes.
9. Snap 10250 clip to each side of the 17452 shaft.
10. Reinstall upper valve body 15114 and upper/ lower power heads.
11. Raw water to inlet lower valve body (16067).
12. Treated water to inlet upper valve body (15114).

